

## iTrust Adapt 1kVA~3kVA UPS

### 用户手册

资料版本 V1.1  
归档时间 2009-11-03  
BOM 编码 31011707

## iTrust Adapt 1kVA ~ 3kVA UPS

### User Manual

Version V1.1  
Revision date November 3, 2009  
BOM 31011707

---

艾默生网络能源有限公司为客户提供全方位的技术支持，用户可与就近的艾默生网络能源有限公司办事处或客户服务中心联系，也可直接与公司总部联系。

艾默生网络能源有限公司  
版权所有，保留一切权利。内容如有改动，恕不另行通知。

艾默生网络能源有限公司  
地址：深圳市南山区科技工业园科发路一号  
邮编：518057  
公司网址：  
[www.emersonnetworkpower.com.cn](http://www.emersonnetworkpower.com.cn)  
客户服务热线：4008876510  
E-mail: [service@emersonnetwork.com.cn](mailto:service@emersonnetwork.com.cn)

Emerson Network Power provides customers with technical support. Users may contact the nearest Emerson local sales office or service center.

Copyright © 2009 by Emerson Network Power Co., Ltd.  
All rights reserved. The contents in this document are subject to change without notice.

Emerson Network Power Co., Ltd.  
Address: No.1 Kefa Rd., Science & Industry Park, Nanshan District 518057, Shenzhen China  
Homepage: [www.emersonnetworkpower.com.cn](http://www.emersonnetworkpower.com.cn)  
E-mail: [support@emersonnetwork.com.cn](mailto:support@emersonnetwork.com.cn)

# 安全注意事项

本手册包含重要安全指导，用户在安装维护 UPS 和电池时需严格遵守。安装运行 UPS 前，请阅读手册全文。

## UPS注意事项

1. 除了内置电池盒，UPS 内部没有用户可操作的部件，请勿擅自打开 UPS 盖板，否则会有触电的危险，且由此导致的 UPS 故障不属于保修范围。
2. UPS 内含电池，即使在未接交流市电的情况下，其输出端仍可能会有电压存在。
3. 当 UPS 需要移动或重新接线时，必须切断市电输入和电池输入，并保证 UPS 已完全关机。否则输出端仍可能有电，有触电的危险。
4. 为确保人身安全和保证 UPS 的正常使用，在使用之前应对 UPS 进行可靠接地。
5. UPS 应用于 IT 配电系统时，必须在中线上安装短路保护装置。
6. 使用环境对 UPS 的使用寿命及可靠性有一定的影响。因此，请注意避免长期在下列工作环境中使用 UPS：
  - 超出技术指标规定（温度：0℃~40℃，相对湿度：0%~95%）的高、低温和潮湿场所
  - 阳光直射或靠近热源的场所
  - 有振动、易受撞的场所
  - 有粉尘、腐蚀性物质、盐份和可燃性气体的场所
7. 请保持 UPS 进、出风口的通畅。通风不畅会导致 UPS 内部的温度升高，使 UPS 内部元器件的寿命缩短，从而影响 UPS 寿命。
8. 不允许液体或其他外来物体进入 UPS 机箱内。
9. 万一周围起火，请使用干粉灭火器，若使用液体灭火器会有触电危险。
10. UPS 的输出电缆不得大于 10m。

## 电池注意事项

1. 勿将电池盖打开或损坏电池，电解液会对皮肤和眼睛造成伤害。如果不小心接触到电解液，应立即用大量清水进行清洗并去医院检查。
2. 电池严禁置于火中，以免爆炸，危及人身安全。
3. 电池可能带有电击和大短路电流危险，操作电池时需摘除手表，戒指和其它金属物件，使用带绝缘手柄的工具。
4. 切勿将电池端子短接，电池短接会引起燃烧。

## 环保信息

UPS 维修：UPS 使用有害环境的元件（电子卡，电子元件）。拆下的元件必须移交专业的收集处理中心。

UPS 拆解：UPS 的拆解必须由专业人员执行。UPS 必须移交专业的收集处理危险物质中心。

## 其它

1. UPS 可用于阻容性（如计算机）、阻性和微感性负载，不宜用于纯感性和纯容性负载（如电动机、空调和复印机等），也不能接半波整流性负载。
2. UPS 应用于下述负载设备前，务必请事先与厂家讨论，其应用、设置、管理和维护等必须有特别的考虑和设计：
  - 与病人生命有直接关联的医疗仪器
  - 电梯等有可能危及人身安全的设备
  - 类似于上述设备的其它设备

# 目 录

第一章 产品介绍 .....	1
1.1 特点 .....	1
1.2 型号 .....	1
1.3 外观和部件 .....	2
1.3.1 外观 .....	2
1.3.2 部件 .....	2
1.4 工作原理 .....	3
1.5 工作模式 .....	4
1.6 规格 .....	5
第二章 安装 .....	7
2.1 开箱检查 .....	7
2.2 安装准备 .....	7
2.3 机械安装 .....	7
2.3.1 塔式安装 .....	7
2.3.2 机架式安装 .....	9
2.4 电缆连接 .....	10
2.4.1 连接输入插头和负载 .....	10
2.4.2 连接电池电缆 .....	10
2.4.3 连接通讯电缆 .....	11
第三章 操作显示面板 .....	12
3.1 控制按钮 .....	12
3.2 指示灯 .....	13
3.2.1 等级指示灯 .....	13
3.2.2 UPS 状态指示灯 .....	14
第四章 操作指导 .....	15
4.1 开机前检查 .....	15
4.2 UPS 开机 .....	15
4.3 手动电池检测 .....	15
4.4 手动旁路 .....	15
4.5 UPS 关机 .....	15
第五章 通讯 .....	17
5.1 SNMP 卡端口 .....	17
5.2 干接点 .....	17

5.2.1 任意模式关机 .....	17
5.2.2 电池模式关机 .....	18
第六章 维护 .....	19
6.1 更换内置电池盒 .....	19
6.2 注意事项 .....	20
6.3 检查 UPS 状态 .....	20
6.4 检测 UPS 功能 .....	21
第七章 故障处理 .....	22
7.1 UPS 症状 .....	22
7.1.1 指示灯 .....	22
7.1.2 声音告警 .....	22
7.2 故障处理 .....	23
附录一 电池箱 .....	25
附录二 有毒有害物质或元素标识表 .....	27

# 第一章 产品介绍

感谢选购 iTrust Adapt 1kVA~3kVA 不间断电源系统（简称 UPS）。

该 UPS 为在线式不间断电源系统，结构紧凑。无论市电通断，UPS 均可不断适应和调节其输出电压，给连接负载提供干净的正弦波电源。该 UPS 用于微型电子设备和其它敏感电子设备的交流供电。

本章详细介绍 UPS 特点、型号、外观和部件、工作原理、工作模式和规格。

## 1.1 特点

该 UPS 包含以下特点：

- 相比于上一代 UPS，该 UPS 提供更加高效的交流电源
- 运用 DSP 全数字控制技术，系统稳定度高，具有自我保护和故障诊断能力
- 拥有极强的智能化电池管理功能，延长电池箱的使用寿命
- 操作显示面板采用 LED 显示，独立显示负载百分比和电池容量，使用户更直观地了解 UPS 工作状态和运行参数
- 2U 厚度，可以随意组装成塔式或者机架式，满足不同用户的安装要求
- 具有风扇的故障自检和自动识别功能
- 具有智能型风扇设计，风扇转速可以根据负载状况自动调整，因而减少耗电，降低噪音
- 有更强的过载能力，在输出过载时，用户只要重新打开输入空开，即可取代过去必须更换保险丝才能使 UPS 恢复工作的情况
- 五种选配卡可提供网络通讯功能
- 最多可外接 4 个电池箱，以延长电池模式供电时间，同时，电池充电的效率更高，耗时更短
- 提供标准 B 型 USB 接口，用于 UPS 和网络服务器或其它计算机系统的通讯
- 提供干接点，实现远程关机功能，使操作更加方便
- 在特定工作条件下，输入功率因数大于 0.99，并根据不同的临界条件而变化
- 具有输出电压选择功能
- 输入 THDI 和输出 THDU 更低
- 提供更多输出插座，方便用户使用

## 1.2 型号

如表 1-1 所示，共有 7 个可选型号。

表1-1 型号

型号	标称额定功率	型号	标称额定功率
UHA1R-0010	1000VA/900W	UHA1R-0020L	2000VA/1800W
UHA1R-0010L	1000VA/900W	UHA1R-0030	3000VA/2700W
UHA1R-0015	1500VA/1350W	UHA1R-0030L	3000VA/2700W
UHA1R-0020	2000VA/1800W		

## 1.3 外观和部件

### 1.3.1 外观

UPS 的外观如图 1-1 所示。



图1-1 UPS 外观

#### 注意

非专业人员禁止打开机箱盖，否则可能触电。

### 1.3.2 部件

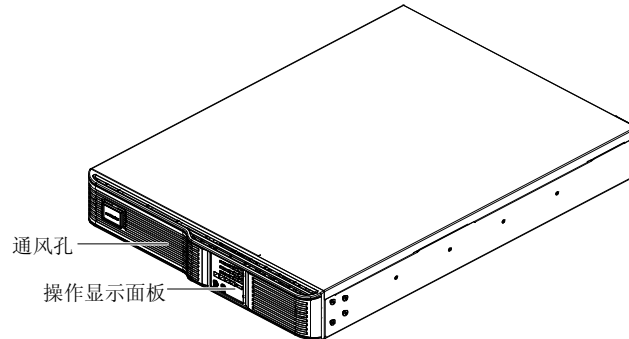
#### 操作显示面板

如图 1-1 所示，操作显示面板位于 UPS 前面板上，提供 LED 指示灯和控制按钮。详细说明参见第三章 *操作显示面板*。

#### 后面板

如图 1-2 所示，UHA1R-0010、UHA1R-0010L、UHA1R-0015、UHA1R-0020 和 UHA1R-0020L UPS 后面板提供如下部件：

- |               |                    |              |
|---------------|--------------------|--------------|
| 1 个拨码开关（带保护盖） | 1 个 SNMP 卡端口（带保护盖） | 1 个 USB 接口   |
| 1 个干接点        | 1 个散热风扇            | 1 个输入空开      |
| 1 个外置电池接口     | 1 个输入插头            | 1 个 C13 输出插座 |
| 3 个国标输出插座     |                    |              |



图1-2 UHA1R-0010、UHA1R-0010L、UHA1R-0015、UHA1R-0020 和 UHA1R-0020L UPS 后面板示意图

如图 1-3 所示，UHA1R-0030 和 UHA1R-0030L UPS 后面板提供如下部件：

- |               |                    |              |
|---------------|--------------------|--------------|
| 1 个拨码开关（带保护盖） | 1 个 SNMP 卡端口（带保护盖） | 1 个 USB 接口   |
| 1 个干接点        | 1 个散热风扇            | 1 个输入空开      |
| 1 个外置电池接口     | 1 个国标输出插座          | 1 个 C13 输出插座 |
| 1 个端子排        | 1 个输入插头            |              |

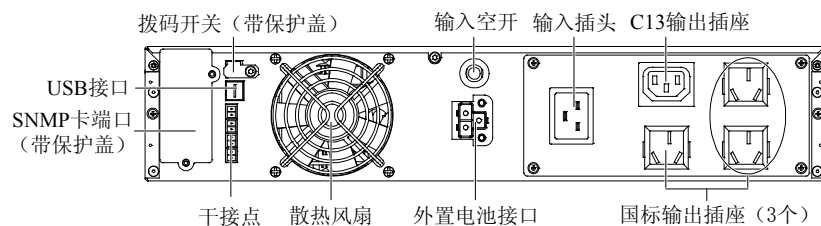

图1-3 UHA1R-0030 和 UHA1R-0030L UPS 后面板示意图

## 1.4 工作原理

UPS 的工作原理如图 1-4 所示。

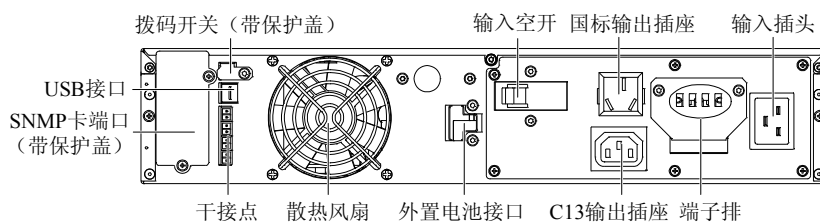

图1-4 工作原理图

UPS 由市电输入、TVSS& EMI/RFI 滤波器、整流器/PFC、逆变器、电池充电器、DC/DC 变换器、电池、动态旁路和 UPS 输出等功能模块组成。

### TVSS& EMI/RFI 滤波器

浪涌防护和电磁干扰（EMI）及无线电频率干扰（RFI）滤波器可以将市电中存在的电源浪涌和干扰减小到最低，以保护敏感设备。同时，该滤波器也能防止 UPS 产生的电源浪涌和干扰影响其他没有使用 UPS 的设备。

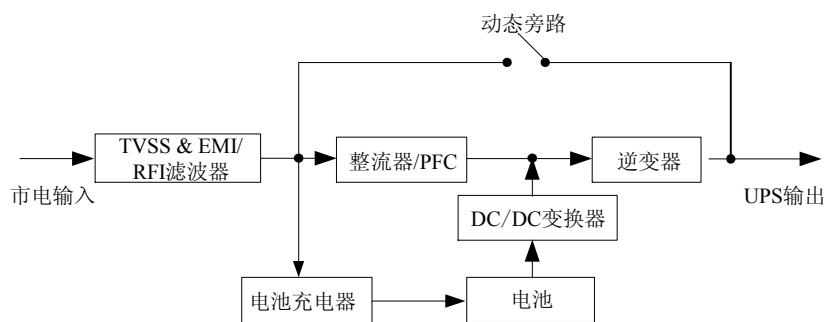
### 整流器/PFC

正常工作模式下，整流器/功率因数校正器（PFC）将交流电转换成可控的直流电，供逆变器使用，保证 UPS 使用的输入电流的波形趋于理想状态。提取正弦波输入电流可达到以下两个目的：

- UPS 尽可能高效地使用市电
- 减少市电谐波

由于整流器的谐波含量很少，使得市电的质量不会受到污染，因此，室内没有使用 UPS 的设备不会因此受到干扰。

### 逆变器

正常工作模式下，逆变器利用 PFC 的直流输出，将其转换成精确，规律的正弦波交流电。市电断电时，逆变器通过 DC/DC 变换器从电池接收所需能量。在这两种工作模式下，UPS 逆变器均可在线式不断产生干净、精确、规律的交流输出电。

### 电池充电器

电池充电器利用市电，精确调节其能量，从而不断对电池进行“浮充”。只要 UPS 接入市电，甚至 UPS 没有开机，电池均可处于充电状态。

### DC/DC 变换器

DC/DC 变换器利用电池的能量，将直流电压升至最佳运行电压值提供给逆变器。该操作使逆变器在最佳效率和电压下不断运行，从而提高可靠性。

### 电池

UPS 使用阀控式、不泄露、铅酸电池。为保持电池的设计寿命，请在周围温度为 0℃~25℃的环境下运行 UPS。

选配件外置电池箱可用于增加电池的运行时间。

### 动态旁路

在 UPS 可能发生故障的情况下，UPS 为市电提供可选路径到连接负载。UPS 发生过载，过温或故障时，UPS 将连接负载自动切换到旁路。

---

#### 注意

旁路不能保护连接设备不受市电干扰。

---

## 1.5 工作模式

UPS 运行模式包括：市电（交流）模式，静态旁路模式，电池模式和电池再充电模式。

本章涉及的指示灯和控制按钮信息，请参见第三章 操作显示面板。

### 市电（交流）模式

在市电（交流）模式下，市电为 UPS 提供能量。滤波器，PFC 和逆变器对市电进行处理，从而给连接负载提供高质量电源。同时，UPS 使电池保持充满电的状态。

### 静态旁路模式

UPS 处于市电（交流）模式时，按一次待机/手动旁路按钮可将 UPS 切换至静态旁路模式。旁路工作时，产生声音告警，旁路指示灯（黄色）亮（如有其它指示灯亮，请参见第七章 故障处理）。静态旁路模式下，市电给 UPS 提供能量且不经逆变器直接为连接负载提供电源。

---

#### 注意

静态旁路模式下关机将导致输出掉电。

---

### 电池模式

电池模式发生在市电极端恶劣或市电掉电的情况下。电池系统通过 DC/DC 变换器给逆变器提供电源，经逆变器生成干净的交流电提供给连接负载。

电池模式下，可听见每 10 秒发生一次的“嘟”声（0.5 秒）告警。当电池电压低时，变成每 5 秒发生一次的“嘟”声（0.5 秒）告警（大约持续 2 分钟，用户可自行配置）。

此时，交流输入指示灯熄灭，电池等级指示灯亮，警示当前市电不可用。每个电池指示灯代表 20% 的容量等级。当容量降低时，指示灯依次熄灭。参见第七章 故障处理。

关于电池运行时间，参见附录一 电池箱。表 2 列出的时间是基于阻性负载和环境温度为 25°C 的情况给出的。为延长该运行时间，可关掉不重要的负载（如闲置的计算机或监控器）或增加选配外置电池箱。

---

#### 警告

1. 电池模式下关机将导致输出掉电。
  2. 如果 UPS 被手动关机，市电恢复正常后，需手动重启 UPS。
  3. 如果通过通讯信号关机，或因为电池耗尽导致 UPS 关机，UPS 将根据配置程序中自动重启选项的设置进行工作。
- 

### 电池再充电模式

一旦市电恢复，UPS 继续市电（交流）模式运行。此时，电池充电器开始重新充电。

---

#### 警告

即使交流输入指示灯熄灭，交流输入仍然可能带电。UPS 运行时，请勿触摸交流输入插头。

---



## 1.6 规格

UPS 的规格见表 1-2 和表 1-3。

表1-2 UHA1R-0010, UHA1R-0010L 和 UHA1R-0015 UPS 规格

参数		产品型号		
		UHA1R-0010	UHA1R-0010L	UHA1R-0015
型号等级		1000VA/900W	1000VA/900W	1500VA/1350W
输入	电压范围 (典型)	标称 220Vac; 根据输出负载可变		
	100%负载	176Vac/280Vac		
	50%~100%负载	120Vac~176Vac, 线形增加		
	功率因数	0.99		
	频率	40Hz~70Hz; 自适应		
	输入插头	IEC 320 C20		
输出	输出插座	1 个 C13 和 3 个 250Vac/10A 国标输出插座		
	电压	220/230/240Vac (用户可配置); ±3%		
	功率因数	0.9		
	频率	50Hz 或 60Hz; ±0.1Hz		
	波形	正弦波		
	市电 (交流) 模式过载	105%至 150%, 60s; 150%至 200%, 2s; >200%, 250ms, 切换至旁路		
电池	类型	阀控式、不泄露, 铅酸电池		
	数量×电压×等级	4×12V×5.0Ah	4×12V×7.2Ah	
	电池制造/部件#	YUASA/NPH5-12 CSB/ HR 1221W	Panasonic/UP-RW1236 CSB/ GP 1272	
	后备时间	参见附录一 电池箱		
	再充电时间	带 100%载放电至 UPS 自动关机, 3 小时充至电池容量的 90% (仅内置电池)		
环境	工作温度	+32°F~+104°F (0°C~+40°C); 根据输出负载可变		
	储存温度	+5°F~+122°F (-15°C~+50°C)		
	相对湿度	0%RH~95%RH, 无冷凝		
	工作海拔高度	104°F (40°C) 时, 高达 10,000 英尺 (3000m), 无需降额		
	储存海拔高度	最大 50,000 英尺 (15000m)		
	噪音	后方 1m 距离, <46dB; 前方或两旁 1m 距离, <43dB	后方 1m 距离, <50dB; 前方或两旁 1m 距离, <48dB	后方 1m 距离, <46dB; 前方或两旁 1m 距离, <45dB
安规认证	安规	CCEE (GB4943-1995) /GB4943		
	RFI/EMI	IEC/EN/AS 62040-2 2nd Ed =CISPR22 Class A		
	浪涌抗扰度	满足 IEC/EN 61000-4-5, 承受 Level 3 (2kV) (火线对地), Level 2 (1kV) (火线之间)		
尺寸(深×宽×高, mm)	单元	500×430×85	500×430×85	500×430×85
	运输	647×607×270	647×607×270	647×607×270
重量 (kg)	单元	20	9	22
	运输	24	13	26

表1-3 UHA1R-0020, UHA1R-0020L, UHA1R-0030 和 UHA1R-0030L UPS 规格

参数		产品型号			
		UHA1R-0020	UHA1R-0020L	UHA1R-0030	UHA1R-0030L
型号等级		2000VA/1800W	3000VA/2700W	3000VA/2700W	3000VA/2700W
输入	电压范围 (典型)	标称 220Vac; 根据输出负载可变			
	100%负载	176Vac/280Vac			
	50%~100%负载	120Vac~176Vac, 线性增加			
	功率因数	0.99			
	频率	40Hz~70Hz; 自适应			
输入插头		IEC 320 C20			
输出	输出插座	1 个 C13 和 3 个 250Vac/10A 国标输出插座	1 个 C13、1 个 250Vac/10A 国标输出插座和 1 个 250Vac/16A 的输出端子排		
	电压	220/230/240Vac (用户可配置); $\pm 3\%$			
	功率因数	0.9			
	频率	50Hz 或 60Hz; $\pm 0.1\text{Hz}$			
	波形	正弦波			
	市电 (交流) 模式过载	105%至 150%, 60s; 150%至 200%, 2s; >200%, 250ms, 切换至旁路			
电池	类型	阀控式、不泄露, 铅酸电池			
	数量×电压×等级	4×12V×9.0Ah	6×12V×9.0Ah		
	电池制造/部件#	Panasonic/UP-RW1245 CSB/HR 1234W F2			
	后备时间	参见附录一 电池箱			
再充电时间		带 100%载放电至 UPS 自动关机, 3 小时充至电池容量的 90% (仅内置电池)			
环境	工作温度	+32°F~+104°F (0°C~+40°C); 根据输出负载可变			
	储存温度	+5°F~+122°F (-15°C~+50°C)			
	相对湿度	0%RH~95%RH, 无冷凝			
	工作海拔高度	104°F (40°C) 时, 高达 10,000 英尺 (3000m), 无需降额			
	储存海拔高度	最大 50,000 英尺 (15000m)			
	噪音	后方 1m 距离, < 48dB; 前方或两旁 1m 距离, <48dB	后方 1m 距离, < 50dB; 前方或两旁 1m 距离, <48dB	后方 1m 距离, < 48dB; 前方或两旁 1m 距离, <48dB	后方 1m 距离, < 50dB; 前方或两旁 1m 距离, <48dB
安规认证	安规	CCEE (GB4943-1995) /GB4943			
	RFI/EMI	IEC/EN/AS 62040-2 2nd Ed =CISPR22 Class A			
	浪涌抗扰度	满足 IEC/EN 61000-4-5, 承受 Level 3 (2kV) (火线对地), Level 2 (1kV) (火线之间)			
尺寸 (深×宽×高, mm)	单元	500×430×85	500×430×85	600×430×85	600×430×85
	运输	647×607×270	647×607×270	747×607×270	747×607×270
重量 (kg)	单元	24	10	28	12
	运输	28	14	32	16

## 第二章 安装

本章介绍 UPS 的安装，包括开箱检查、安装准备、机械安装和电缆连接。

### 2.1 开箱检查

UPS 到货后，打开包装，检查以下项目：

1. 目测 UPS 外观，检查 UPS 是否在运输中有碰撞损坏。如发现运输损坏现象，请立即通知承运商。
2. 对照发货附件清单，检查随机附件型号是否齐全、正确。如发现附件缺少或型号不符，请立即通知经销商。

### 2.2 安装准备

#### 安装环境

1. 请勿将 UPS 安装在露天环境下，UPS 的安装环境应满足 UPS 的规格要求（参见 1.6 规格）。
2. UPS 安装环境应通风良好，远离水源、热源和易燃易爆物品，避免阳光直射，避免将 UPS 安装在有粉尘、挥发性气体、腐蚀性物质和盐份过高的环境中。

#### 注意

UPS 在温度高于 25℃ 的环境中工作会降低电池寿命。

#### 安装间距

UPS 的前面板和后面板应与墙壁或相邻设备间保持至少 200mm 的距离；同时，避免任何物品遮盖 UPS 前面板和后面板的通风孔，以免阻碍 UPS 的通风散热，造成 UPS 内部温度升高，影响 UPS 的使用寿命。

### 2.3 机械安装

安装方式有两种：塔式安装和机架式安装，取决于可用空间和使用考虑。用户可以根据实际情况，选择合适的安装方式。

#### 2.3.1 塔式安装

#### 注意

用户可以选择多种安装组合：单个 UPS、单个 UPS 带一个或多个电池箱，各种安装组合的安装方法完全相同。

安装方法如下：

第一步：从附件中取出支撑座，其外观如图 2-1 所示。



图2-1 支撑座

第二步：如选配外置电池箱连接至 UPS，以提供附加的电池运行时间，可从电池箱附件中取出中间座，将中间座和支撑座通过连接扣组装在一起，如图 2-2 所示。

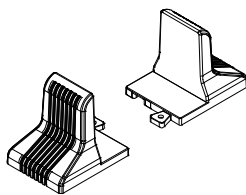

图2-2 安装带中间座的支撑座

### 注意

最多可用 4 个外置电池箱，但是每个电池箱会延长电池的再充电时间。

第三步：调整 UPS 操作显示面板和 LOGO 的方向。

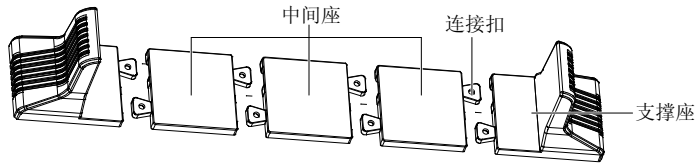
1. 轻轻拆下 UPS 的前塑胶面板，如图 2-3 所示。



图2-3 拆下前塑胶面板

2. 将操作显示面板轻轻拉出，顺时针旋转 90 度然后按回原位，如图 2-4 所示。

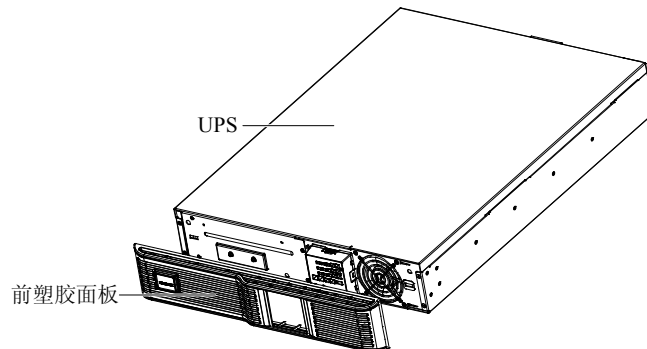

图2-4 旋转操作显示面板

3. 将前塑胶面板上的 LOGO 轻轻拉出，顺时针旋转 90 度然后按回原位。旋转完成后前塑胶面板如图 2-5 所示。

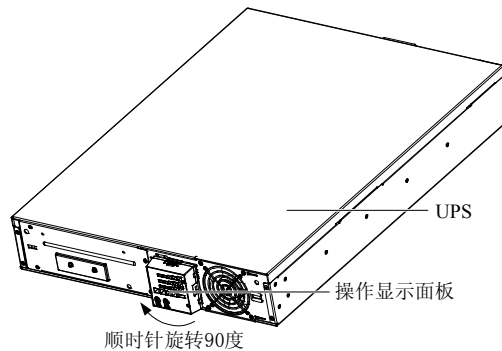

图2-5 旋转 LOGO 完成示意图

4. 将前塑胶面板装回 UPS。此时，UPS 的操作显示面板和 LOGO 已顺时针旋转 90 度，给用户提垂直视图。

第四步：将 UPS（和电池箱）放置于支撑座上，每台 UPS 需要安装两组支撑座，如图 2-6 所示。



图2-6 塔式安装

### 注意

两组支撑座尽可能远离放置，以防倾倒 UPS。建议 UPS 前后面板和对应支撑座之间保持 70mm 的距离。

## 2.3.2 机架式安装

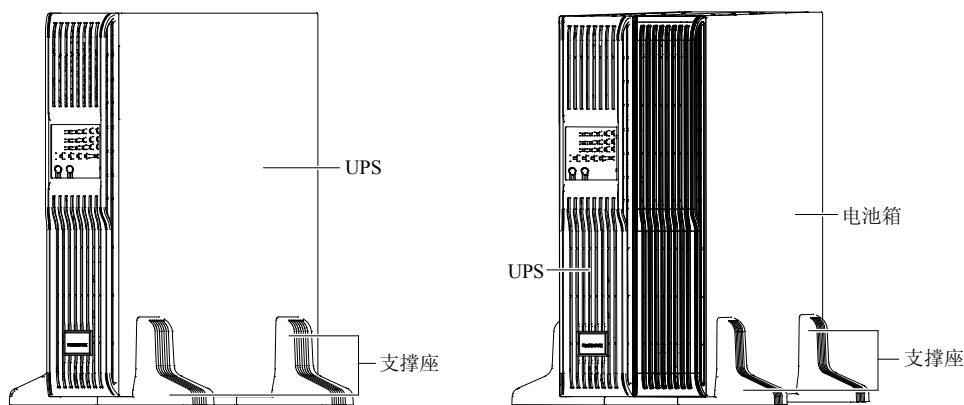
### 注意

1. 用户可以选择多种安装组合：单个 UPS、单个 UPS 带一个或多个电池箱，各种安装组合的安装方法完全相同。
2. 由于电池箱较重，必须首先安装电池箱，安装时需两人以上同时安装，并从最底下的电池箱开始安装。

机架式安装是通过挂耳将 UPS 和电池箱固定在机架上的。

安装方法如下：

1. 从附件中取出挂耳（2 个）和 M4×10 螺钉（8 颗），通过安装孔 1 用螺钉将挂耳固定在电池箱上，如图 2-7 所示。



图2-7 安装挂耳

2. 将电池箱放置于机架的导轨上（禁止通过挂耳搬运电池箱），推入电池箱直到推不进去为止，从附件中取出 M6×16 螺钉（4 颗），通过挂耳上的安装孔 2 将电池箱固定在机架上，如图 2-8 所示。

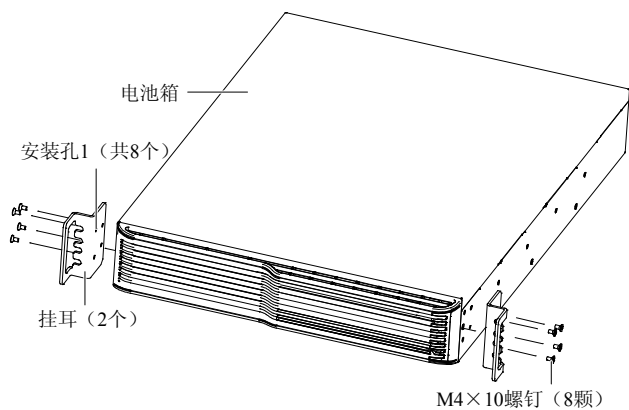

图2-8 安装电池箱

3. UPS 的安装方法与电池箱完全相同。UPS 安装在电池箱上方，单个 UPS 和单个电池箱的标准机型机架式安装方式，如图 2-9 所示。

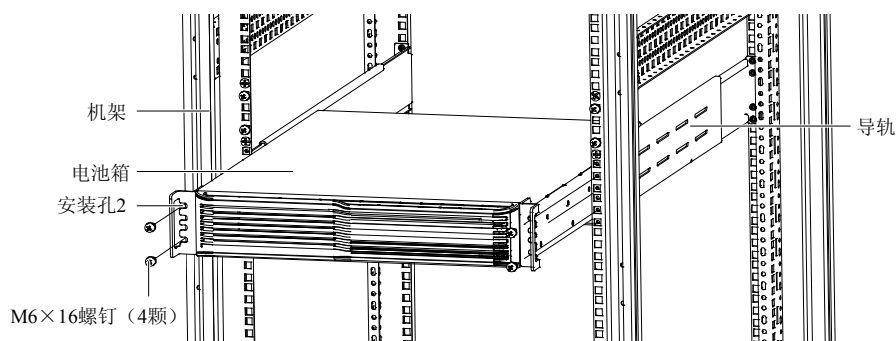

图2-9 单个 UPS 和单个电池箱标准机型机架式安装

## 2.4 电缆连接

UPS 后面板提供输入插头和输出插座，详细信息参见 1.3.2 部件。电池电缆和电池箱一起发货。

### 2.4.1 连接输入插头和负载

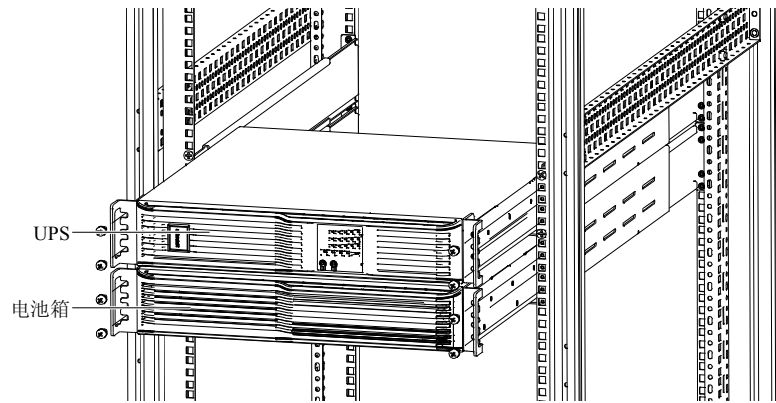
注意

1. 确认所有负载均已关闭。
2. 准备一个墙壁插座作为输入电源。依据国家或当地条例，插座必须由空开妥善保护且可靠接地。
3. 建议选择与 UPS 输入空开一个系列的上级空开，且上级空开应大于 UPS 输入空开。

UPS 后面板配备的输入空开的规格见表 2-1。

表2-1 UPS 后面板配备的输入空开规格

型号	额定空开	型号	额定空开
UHA1R-0010	10A	UHA1R-0020L	16A
UHA1R-0010L	10A	UHA1R-0030	25A
UHA1R-0015	10A	UHA1R-0030L	25A
UHA1R-0020	16A		

连接步骤

1. 将所有负载连接至 UPS 后面板的输出插座。

 注意

建议单个输出插座不要输出过载。

2. 将 UPS 的输入插头插入墙壁插座。

### 2.4.2 连接电池电缆

 注意

电池箱里的电池必须为同一厂家，同一型号，同一新旧电池。

连接步骤

1. 断开电池箱的输入空开。

2. 从电池箱附件中取出电池电缆，将电池电缆的一端插至 UPS 后面板的外置电池接口，另一端插至电池箱后面板上的任一电池接口。
3. 闭合外置电池箱的电池空开。
4. 使用所附的配置程序重新设置连接至 UPS 的外置电池箱数。有关大约的电池运行时间，参见附录一 电池箱。

---

 注意

如果没有重新设置外置电池箱数量，UPS 可能产生告警。

---

### 2.4.3 连接通讯电缆

连接通讯电缆包括：连接 USB 通讯电缆和选配卡通讯电缆。

#### 连接 USB 通讯电缆

1. 从附件中取出 USB 通讯电缆。
2. 将 USB 通讯电缆的一端插至 UPS 后面板上的 USB 接口（位置见图 1-2 和图 1-3）。
3. 将 USB 通讯电缆的另一端插至上位机的 USB 接口。

#### 连接选配卡通讯电缆

选配卡安装和通讯电缆连接步骤如下：

1. 拆下 SNMP 卡端口保护盖，妥善保管保护盖，以备将来使用。
2. 将选配卡插入 SNMP 卡端口，用螺钉拧紧。
3. 通过网络连接线（用户自配）将 UPS 连接到计算机网口。
4. 设置选配卡，设置方法参见选配卡的用户手册。

## 第三章 操作显示面板

本章介绍操作显示面板的控制按钮和指示灯。

操作显示面板位于 UPS 的前面板（如图 1-1）。操作显示面板提供 2 个控制按钮和 7 种指示灯，如图 3-1 所示。



图3-1 操作显示面板

### 3.1 控制按钮

操作显示面板提供两个控制按钮：开机/告警消音/手动电池检测按钮和待机/手动旁路按钮。

#### 开机/告警消音/手动电池检测按钮

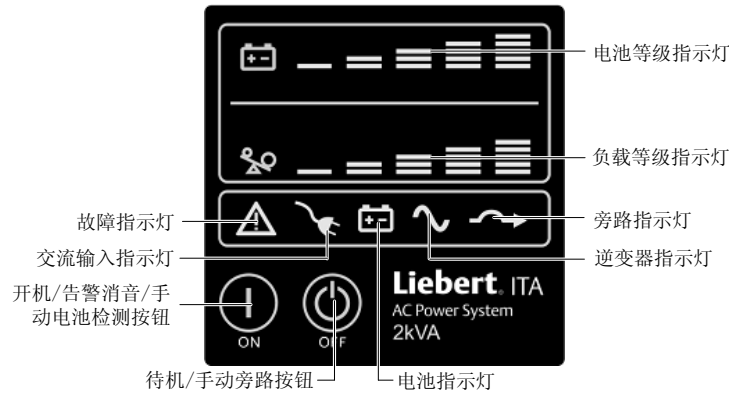
开机/告警消音/手动电池检测按钮控制连接负载的输出电源，拥有三种功能，见表 3-1 所示。

表3-1 开机/告警消音/手动电池检测按钮功能

功能	操作	描述
开机	按住该按钮持续 3 秒	启动 UPS
告警消音 <sup>1</sup>	按住该按钮持续 0.5 秒以上	消除告警声音 <sup>2</sup>
手动电池检测	UPS 运行于市电（交流）模式且无告警情况存在，按住该按钮持续 0.5 秒以上	开启手动电池检测
注意： 1. 低电池电压和旁路提醒告警不能消音。 2. 告警消音以后，当检测到新告警时，UPS 将重新激活告警系统		

#### 待机/手动旁路按钮

待机/手动旁路按钮控制连接负载的输出电源，拥有双重功能，见表 3-2 所示。

表3-2 待机/手动旁路按钮功能

功能	操作	描述
待机	4 秒内按两次该按钮 <sup>1</sup>	关闭 UPS，移除所有连接负载的电源
手动旁路	按一次该按钮 <sup>2</sup>	开启手动旁路，将连接负载切换至可用内部旁路
注意： 1. 关闭 UPS 之前，对所有连接负载进行必要的关机步骤。 2. 如果由于电压或频率问题，导致旁路不可用，该操作无效		



## 3.2 指示灯

操作显示面板提供 7 种指示灯（位置见图 3-1），可根据其应用范围分为两组：等级指示灯和 UPS 状态指示灯。











### 3.2.1 等级指示灯

#### 电池等级指示灯

电池等级指示灯包括 5 个由 LED 条组成的格段，用于显示电池容量等级。

UPS 电池容量等级以 20% 的增幅（±5%）显示，电池等级指示灯的状态见表 3-3 所示。





表3-3 电池等级指示灯

电池等级	指示灯状态	
	充电	放电
0~20%	 闪 灭 灭 灭 灭	 亮 灭 灭 灭 灭
21%~40%	 亮 闪 灭 灭 灭	 亮 亮 灭 灭 灭
41%~60%	 亮 亮 闪 灭 灭	 亮 亮 亮 灭 灭
61%~80%	 亮 亮 亮 闪 灭	 亮 亮 亮 亮 灭
81%~100%	 亮 亮 亮 亮 闪	 亮 亮 亮 亮 亮

#### 负载等级指示灯

负载等级指示灯包括 5 个由 LED 条组成的格段，用于显示 UPS 输出上的相关负载。UPS 输出上的负载等级以 25% 的增幅（±5%）显示，负载等级指示灯的状态见表 3-4 所示。

表3-4 负载等级指示灯

负载等级	指示灯状态	负载等级	指示灯状态
0~25%	 亮 灭 灭 灭 灭	26%~50%	 亮 亮 灭 灭 灭
51%~75%	 亮 亮 亮 灭 灭	76%~100%	 亮 亮 亮 亮 灭
>100%	 亮 亮 亮 亮 亮		

### 3.2.2 UPS 状态指示灯

UPS 状态指示灯包括 5 个指示灯：故障指示灯、交流输入指示灯、电池指示灯、逆变器指示灯和旁路指示灯。其描述见表 3-5 所示。

表3-5 UPS 状态指示灯

UPS 状态指示灯	图标	颜色	描述
故障指示灯		红色	UPS 检测到故障时亮，无故障时灭
交流输入指示灯		绿色	市电正常时亮，掉电或电压超限时灭
电池指示灯		黄色	电池供电时亮，未供电时灭
逆变器指示灯		绿色	逆变器供电时亮，未供电时灭
旁路指示灯		黄色	旁路供电时亮，未供电时灭，电压超限时闪

## 第四章 操作指导

本章介绍 UPS 开机前检查、开机、手动电池检测、手动旁路和关机。

### 注意

电池在出厂时已充满电，但经过运输和存储，电量会有所损失，因此在第一次使用 UPS 时应充电 3 小时，以保证有足够的备用时间。

### 4.1 开机前检查

UPS 开机前，需要检查以下内容：

1. UPS 输入插头和输出插座是否正确、可靠连接。
2. 电池电缆是否可靠连接。
3. 通讯电缆是否可靠连接。

### 4.2 UPS 开机

1. 闭合输入空开（位置见图 1-2 和图 1-3）。
2. 按住开机/手动电池检测按钮持续 3 秒，打开 UPS。
3. 打开连接负载。

此时，UPS 给负载提供调节好的电源。

### 4.3 手动电池检测

UPS 运行于市电模式且无告警时，按住开机/手动电池检测按钮持续 0.5 秒以上，开启手动电池检测。

- 如果 5 个 LED 格段中只有前 2 个亮，UPS 需再对电池充电 24 小时
- 24 小时后，重新检测电池
- 电池重新检测以后，如果 5 个 LED 格段中只有 2 个亮，联系当地经销商
- 如果开启手动电池检测以后，电池自检失败，请检查电池连接，并让 UPS 再给电池充电 1 小时，然后再次开启手动电池检测
- 如果仍然电池自检失败，请更换电池，并联系当地经销商

### 4.4 手动旁路

按一次待机/手动旁路按钮，UPS 将连接负载切换至内部旁路。如果由于电压或频率问题，导致内部旁路不可用，该操作无效。旁路工作时，产生声音告警，旁路指示灯（黄色）亮（如有其它指示灯亮，请参见第七章 故障处理）。

### 注意

旁路模式的过载是按照电流过载来判断的，不是按照功率过载判断的。

### 4.5 UPS 关机

1. 4 秒内按两次待机/手动旁路按钮，关闭 UPS，所有连接负载断电。

2. UPS 关机后，断开输入电缆插头。30 秒后，所有指示灯熄灭，风扇停止运行。
3. 如果 UPS 有外置电池箱，将外部开关置于 OFF。

此时，UPS 停止输出，负载断电。

## 第五章 通讯

UPS 后面板配备一个 SNMP 卡端口，一个标准 B 型 USB 接口和 4 对干接点，以提供高级通讯和监控选择。

本章通过 SNMP 卡端口和干接点两方面介绍 UPS 通讯。

### 警告

为保证安规和电池兼容性，信号线缆应与电源线缆隔离并分开运行。

## 5.1 SNMP 卡端口

SNMP 卡端口适用于五种选配卡，具体信息见表 5-1。

表5-1 选配卡

选配卡	功能
UF-RS485 卡	实现 RS232 信号和 RS485 信号的相互转化
UF-DRY320 5k UPS 用干接点扩展卡	向远端提供 4 路继电器开关信号输出、提供三路开关信号输入、提供四路模拟量采集功能
UF-DRY310 UPS 用干接点卡	向远端提供 4 路继电器开关信号输出
Intellislot UPS 用 SNMP 卡	通过 USB 与 UPS 通信以获取 UPS 信息；可通过 USB 端口设置，提供网络接口供后台通过网络访问
Liebert NX UPS 用 MODBUS 卡	根据公司统一规划选用。通过 USB 与 UPS 通信以获取 UPS 信息，所用协议为 MODBUS 协议

这五种卡提供配置程序、监控 UPS 和输出电压选择功能，详细信息参见各卡的用户手册。

## 5.2 干接点

干接点包括 8 个针脚，如图 5-1 所示。其定义见表 5-2。



图5-1 干接点

表5-2 针脚定义

针脚	丝印	定义
1&2	1, 2	任意模式关机
3&4	3, 4	电池模式关机
5&6	5, 6	电池低电压模式
7&8	7, 8	电池模式

### 5.2.1 任意模式关机

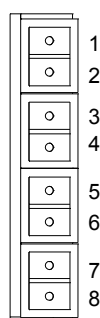
任意模式关机目的在于通过关闭整流器、逆变器和静态空开关闭 UPS 输出，负载断电。

任意模式关机可以通过本地和远程执行，描述如下：

- 本地任意模式关机可以通过使用跳线帽短接针脚 1 和针脚 2 来执行
- 远程任意模式关机可以通过开关来执行，该开关连接至针脚 1 和针脚 2，并安装在远处

任意模式关机的动作将被记录在历史日志的事件中。

#### 注意

1. 远程关机将通过任意模式关机的常开或常闭触点来执行。
2. 12Vdc, 50mA 的电流源可来自 UPS。
3. 用于远程连接时，可通过端子排连接器连接至 UPS。
4. 任意模式关机应遵从当地接线条例法规。

---

#### 警告

当用户使用 Pin1 和 Pin2 关闭 UPS 输出，并且设置自动使能输出的选项时，如果用户改变 Pin1 和 Pin2 的连接，UPS 将重新启动且无告警。

---

### 5.2.2 电池模式关机

电池模式关机目的在于：当 UPS 仅运行于电池模式，通过关闭整流器、逆变器和静态空开来关闭 UPS，使负载断电。电池模式关机可以通过本地和远程执行，描述如下：

- 本地电池模式关机可以通过使用跳线帽短接针脚 3 和针脚 4 来执行
- 远程电池模式关机可以通过开关来执行，该开关连接至针脚 3 和针脚 4，并安装在远处

电池模式关机的动作将被记录在历史日志的事件中。

#### 注意

1. 远程关机将通过常开触点来执行。
2. 12Vdc, 50mA 的电流源可来自 UPS。
3. 用于远程连接时，可通过端子排连接器连接至 UPS。
4. 电池模式关机应遵从当地接线条例法规。
5. 信号必须持续 1.5 秒以上。
6. 电池关机信号不会导致迅速关机，而将启动为时 2 分的关机计时器，该计时器一经启动不能停止。当市电恢复，UPS 是否重新开机取决于自动重启设置。

## 第六章 维护

本章介绍更换内置电池盒，注意事项、检查 UPS 状态和检测 UPS 功能。

### 6.1 更换内置电池盒

用户可安全更换 UPS 的内置电池盒。更换之前请阅读安全须知。联系当地经销商获取替换电池盒的编码和价格。

#### 电池充电

电池为阀控式、不泄露、铅酸电池，电池应保持充电状态以达到设计寿命。UPS 连接至市电时会不断对电池进行充电。当需长时间储存 UPS 时，建议每 4 至 6 个月给 UPS 上电 24 小时以上，以保证电池充满电。

#### 安全须知

电池可引发触电危险和大短路电流。更换电池盒之前需注意以下安全事项：

- 摘除戒指、手表或其它金属物件
- 戴橡胶手套，穿绝缘鞋
- 使用带有绝缘手柄的工具
- 不要将工具或其它金属物件置于电池上
- 如果替换电池盒遭到损坏或有泄露迹象，请立即联系当地经销商
- 不要将电池置于火中，否则电池可能爆炸
- 依据当地法规处理、运输和回收电池

#### 电池盒更换步骤

第 1 步：轻轻拆下 UPS 的前塑胶面板。

第 2 步：拧松、拆除电池门上的 6 个螺钉，如图 6-1 所示。将电池门收好以备组装。



图6-1 拆下前塑胶面板和电池门

第 3 步：轻轻拉出电池线缆，断开电池插头和电池插座连接，如图 6-2 所示。

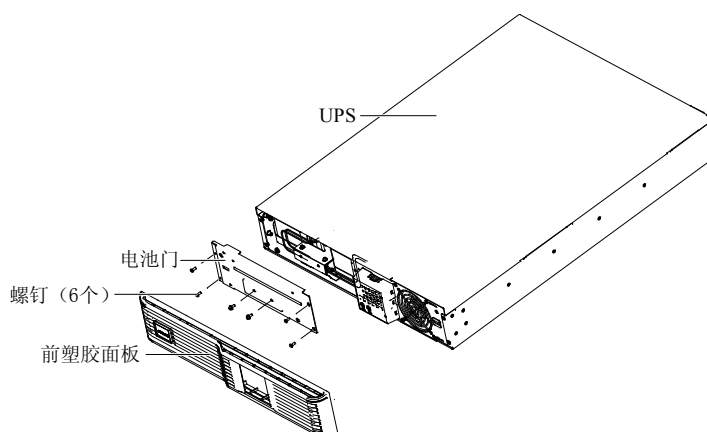

图6-2 断开电池插头和电池插座连接（前视图）

第 4 步：抓住电池拉手，将内置电池盒拉出 UPS，如图 6-3 所示。

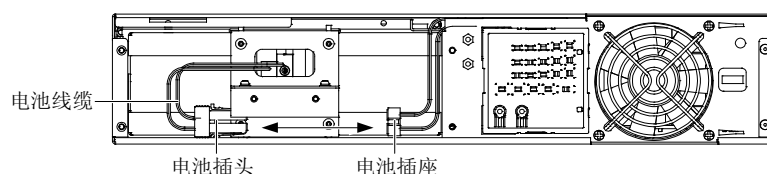

图6-3 拉出内置电池盒

第 5 步：打开新内置电池盒的包装，小心不要损坏电池盒。

对比新旧内置电池盒，确认二者相同。如果相同，继续第 6 步；否则停止操作，联系当地经销商。

第 6 步：对准并推入新的内置电池盒。

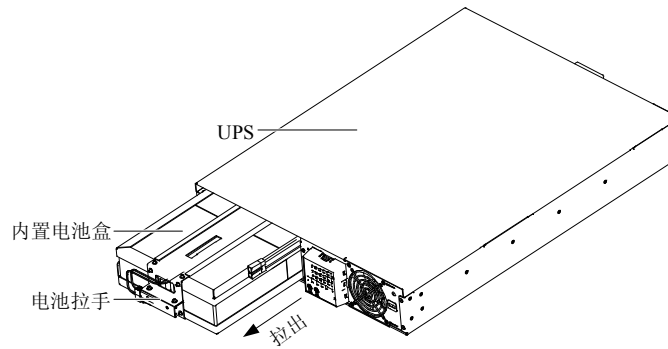
第 7 步：重新连接电池插头和电池插座，轻轻将电池线缆和内置电池盒推入 UPS。

第 8 步：用 6 个螺钉重新装上电池门。

第 9 步：重新装上 UPS 的前塑胶面板。

#### 注意

1. 严禁对内置电池盒进行热插拔。
2. UPS 在电池模式下运行时，禁止更换内置电池盒。否则会导致输出掉电和负载断电，甚至危及人身安全！

## 6.2 注意事项

虽然 UPS 在保证人身安全的前提下进行设计和生产，不适当的使用仍然可能导致触电或火灾。为保证安全，请遵守以下注意事项：

- 清洁 UPS 之前，UPS 需关机
- 使用干布清洁 UPS。不要使用液体或喷雾清洁剂
- 不要堵塞或将杂物塞进 UPS 通风孔或其它开口
- 不要将 UPS 电源线放在可能遭到损坏的地方

## 6.3 检查 UPS 状态

建议每半年检查一次 UPS 的工作状态。

检查内容包括：

1. 检查 UPS 有无故障。故障指示灯是否亮，是否有故障报警。
2. 检查 UPS 是否工作于旁路。正常情况下，UPS 应以市电逆变供电模式运行；如果 UPS 以旁路供电模式运行，需确认原因，如：人为动作、过载、内部故障等。
3. 检查电池是否处于放电状态。市电正常情况下，电池不应放电；如果 UPS 以电池模式运行，需确认原因，如：市电停电、电池自检、人为动作等。



## 6.4 检测 UPS 功能

---

### 注意

UPS 功能检测操作可能导致负载断电!

---

建议每半年进行一次 UPS 功能检测。

在进行功能检测前先确认市电正常并做好负载设备的数据备份。操作步骤如下：

1. 按待机/手动旁路按钮，检查蜂鸣器、指示灯是否正常。
2. 按开机/告警消音/手动电池检测按钮，再次检查指示灯显示是否正常，UPS 是否正常工作。
3. 在逆变运行后（逆变器指示灯亮），按开机/告警消音/手动电池检测按钮 3 秒，启动电池自检，检测电池是否正常。如果发现电池有问题，应立即查明问题并采取措施解决。

## 第七章 故障处理

本章介绍用户可能碰到的各种 UPS 症状以及在 UPS 故障时如何进行故障处理。使用以下信息判断是否外部原因导致问题以及如何补救。

### 7.1 UPS 症状

以下症状表示 UPS 发生故障。

1. 相关指示灯亮，UPS 检测到故障。
2. 产生声音告警，提示用户 UPS 需要检查。

#### 7.1.1 指示灯

除故障指示灯亮，一个或多个电池等级指示灯的 LED 格段可能同亮，给用户提提供诊断帮助，如图 7-1 所示。指示灯描述见表 7-1。



图7-1 电池等级指示灯

表7-1 指示灯描述

指示灯	状态	诊断问题/声音告警
A~E	亮	输出过载切换至旁路（0.5 秒“嘟”响，每 0.5 秒响一次）
故障指示灯	亮（红色）	
A	亮	过温切换至旁路（1 秒“嘟”响，每 4 秒响一次）
故障指示灯	亮（红色）	
B	亮	直流母线过压切换至旁路（1 秒“嘟”响，每 4 秒响一次）或旁路频率异常情况下输出短路
故障指示灯	亮（红色）	
C	亮	DC/DC 电源失效切换至旁路（1 秒“嘟”响，每 4 秒响一次）
故障指示灯	亮（红色）	
D	亮	PFC 失效（1 秒“嘟”响，每 4 秒响一次）
故障指示灯	亮（红色）	
E	亮	逆变器失效切换至旁路（1 秒“嘟”响，每 4 秒响一次）
故障指示灯	亮（红色）	
A&C	亮	UPS 电池自检失败（2 秒“嘟”响，每 60 秒响一次）
故障指示灯	亮（红色）	
C&E	亮	通讯命令 UPS 关机（USB 接口或 SNMP 卡端口）（无声音告警）
故障指示灯	亮（红色）	
A&B	亮	UPS 故障（包括双风扇失效，特定情况下单风扇失效以及电池充电器失效）和持续声音告警
故障指示灯	亮（红色）	
电池指示灯	闪	内置电池不可用（常鸣）检查电池连接，完全关机然后重启 UPS
交流输入指示灯	闪	市电接反或 UPS 没有可靠接地；UPS 将常鸣且在待机状态下不能启动
旁路指示灯	闪	市电电压或频率超限；旁路不可用
注意：A~E 指示灯如图 7-1 所示		

#### 7.1.2 声音告警

声音告警和指示灯相互结合，告知用户 UPS 运行状态的改变。声音告警描述见表 7-2。

表7-2 声音告警描述

序号	情况	告警
1	电池放电	0.5 秒“嘟”响，每 10 秒响一次
2	电池电压低	0.5 秒“嘟”响，每 5 秒响一次
3	UPS 故障，负载切换至旁路	1 秒“嘟”响，每 4 秒响一次
4	UPS 故障，无输出至负载	持续响
5	过载	0.5 秒“嘟”响，每 0.5 秒响一次
6	电池更换	2 秒“嘟”响，每 60 秒响一次
7	无电池	持续响
8	接线问题（包括市电接反或 UPS 没有可靠接地）	持续响
9	旁路提醒	1 秒“嘟”响，每 2 分响一次

## 7.2 故障处理

UPS 出现异常或故障时，请首先按表 7-3 进行检查和故障排除。如果问题仍然存在，请联系客户服务热线：4008876510 寻求技术支持。

表7-3 故障处理表

序号	问题	原因	解决方案
1	按下开机/告警消音/手动电池检测按钮，UPS 未能启动	UPS 短路或过载	确认 UPS 关机。断开所有负载，确认输出插座上没有连接任何东西。确认负载没有缺陷或内部短路
2	电池指示灯亮	UPS 没有接入市电	UPS 运行于电池模式，确认 UPS 安全插入墙壁插座
		UPS 输入保护保险断开	UPS 运行于电池模式，保存数据，关闭计算机。更换 UPS 保险然后重启 UPS
		市电电压超出 UPS 输入范围	UPS 运行于电池模式，保存数据，关闭计算机。确认市电电压在 UPS 的可接受范围内
3	UPS 的电池后备时间减少	电池没有充满电	让 UPS 接入市电 24 小时以上，重新给电池充电
		UPS 过载	检查负载等级指示灯，减少 UPS 所带的负载
		由于使用时间过长，电池不能充满电	更换电池。联系当地经销商购买替换电池套装
4	故障指示灯、旁路指示灯和电池等级指示灯的所有 LDE 格段均亮	UPS 过载或负载故障	检查负载等级指示灯，移除不必要的负载。重新计算负载，减少连接至 UPS 的负载数量。检查负载是否故障
5	故障指示灯、旁路指示灯和 A 诊断指示灯亮	由于温度原因 UPS 关机，负载切换至旁路	确认 UPS 没有过载，通风孔没有堵塞。等待 30 分钟让 UPS 冷却，然后重启 UPS。如果 UPS 不能重启，联系当地经销商
6	故障指示灯、旁路指示灯和 B 诊断指示灯亮	UPS 内部直流母线过压（若旁路指示灯闪烁，则为市电频率异常时输出短路）	确认负载没有短路，如果没有，则 UPS 需要维护，联系当地经销商
7	故障指示灯、旁路指示灯和 C 诊断指示灯亮	UPS DC/DC 故障	UPS 需要维护，联系当地经销商
8	故障指示灯、旁路指示灯和 D 诊断指示灯亮	UPS PFC 故障	UPS 需要维护，联系当地经销商
9	故障指示灯、旁路指示灯和 E 诊断指示灯亮	UPS 逆变器故障	UPS 需要维护，联系当地经销商
10	故障指示灯和 A&C 诊断指示灯亮	UPS 电池自检失败	更换电池。联系当地经销商
11	故障指示灯、旁路指示灯和 C&E 诊断指示灯亮	通讯端口发送命令关闭 UPS	UPS 从连接计算机接收到信号或命令。如果这不是有意造成的，确认所用信号线符合系统要求。联系当地经销商
12	故障指示灯和 A&B 诊断指示灯亮	UPS 故障（包括双风扇失效，特定情况下单风扇失效以及电池充电器失效）和持续告警	确认风扇没有堵塞。如果故障无法清除，联系当地经销商

序号	问题	原因	解决方案
13	交流输入指示灯闪	UPS 检测到市电接反或 UPS 没有可靠接地；UPS 将常鸣且在待机状态下不能启动，只有当市电第一次用于输入时发生。一旦 UPS 开始运行，除非正确更改了输入接线，否则交流输入指示灯仍然闪烁	联系专业电工更改站点布线
14	电池指示灯闪	电池不可用；常鸣	检查电池连接，完全关机然后重启 UPS。 注意：UPS 运行时，如果断开电池连接，将在下次电池检测中被检测出
15	旁路指示灯闪	因为电压或频率超出可接受范围，导致旁路异常	交流输入给 PFC 输入供电并作为旁路电源。如果交流输入存在但是其电压或频率超出安全操作负载的可接受范围，旁路将失效，该指示灯亮，表示旁路不可用
注意：A~E 指示灯如图 7-1 所示			

需要向我公司或经销商反映故障情况时，请务必记录并告知设备型号和设备编码（UPS 机箱背面条码）。

## 附录一 电池箱

### 外观

UPS 可连接选配电池箱。电池箱后面板提供电池接口和输入空开，如图 1 所示。



图1 电池箱

### 注意

1. 因为电池环路和交流输入没有绝缘处理，在电池端口和接地点之间可能存在危险电压，禁止触碰这些元件。
2. 随电池箱所附的标准电池电缆长为 0.65m。如果用户需要不同长度的电缆，请联系经销商。

### 电池箱规格

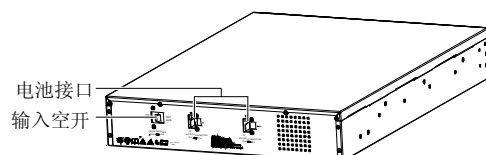
表1 电池箱规格

参数		型号	
		Adapt-72VBATT	Adapt-48VBATT
适用 UPS 型号		UHA1R-0030 和 UHA1R-0030L	UHA1R-0020、UHA1R-0020L、 UHA1R-0015、UHA1R-0010、 UHA1R-0010L
尺寸： (深×宽×高，mm)	单位	600×430×85	500×430×85
	运输	735×595×250	635×595×250
重量 (kg)	单位	38	26
	运输	42	28
电池参数	类型	阀控式、不泄露、铅酸电池	
	数量×电压×等级	2×6×12V×9.0Ah	2×4×12V×9.0Ah
	电池制造商/型号	Panasonic/UP-RW1245 CSB/HR 1234W F2	Panasonic/UP-RW1245 CSB/HR 1234W F2
	后备时间	见表2 电池运行时间	
环境	工作温度	+32°F~+104°F (0°C~+40°C)	
	储存温度	+19°F~+104°F (-15°C~+40°C)	
	相对湿度	0%RH~95%RH, 无冷凝	
	工作海拔	104°F (40°C) 时, 高达 10,000 英尺 (3000m), 无需降额	
	储存海拔	最大 50,000 英尺 (15000m)	
	噪音	后方 1m 处, <50dBA; 前方或两旁 1m 处, <45dBA	
安规认证	安规	CCEE (GB4943-1995) /GB4943	
	RFI/EMI	IEC/EN/AS 62040-2 2nd Ed =CISPR22 Class A	
	浪涌抗扰度	满足 IEC/EN 61000-4-5, 承受 Level 3 (2kV) (火线对地), Level 2 (1kV) (火线之间)	

## 电池运行时间

表2 电池运行时间

电池数	负载	运行时间（单位：分钟）			
		1KVA	1.5KVA	2KVA	3KVA
内置电池	10%	52	112	115	115
	20%	35	47	44	44
	30%	20	26	25	25
	40%	17	20	16	16
	50%	12	13	12	12
	60%	10	10	9	9
	70%	8	8	7	7
	80%	6	7	5	5
	90%	5	5	5	5
内置电池+1个外置电池箱	10%		412	400	220
	20%	136	202	116	120
	30%	115	110	64	102
	40%	90	86	48	60
	50%	66	58	39	52
	60%	58	48	29	44
	70%	50	38	23	34
	80%	43	32	21	27
	90%	41	28	17	25
内置电池+2个外置电池箱	10%		840	540	170
	20%	264	348	231	144
	30%	154	208	138	124
	40%	136	154	99	108
	50%	116	110	64	102
	60%	102	93	55	74
	70%	82	84	48	60
	80%	72	64	41	54
	90%	60	53	36	48
内置电池+3个外置电池箱	10%	620	860	720	295
	20%	360	480	362	230
	30%	224	310	210	174
	40%	162	212	144	130
	50%	128	196	108	114
	60%	124	138	60	105
	70%	116	110	64	102
	80%	108	96	61	80
	90%	80	90	52	68
内置电池+4个外置电池箱	10%	1320	1260	960	236
	20%	640	780	450	204
	30%	500	400	270	184
	40%	224	310	189	168
	50%	174	212	144	132
	60%	136	180	116	120
	70%	140	156	104	108
	80%	124	132	88	103
	90%	116	110	84	102
	100%	109	100	64	84

注意：大约放电时间以分钟为单位，且在 77°F（25°C）下带阻性负载

## 附录二 有毒有害物质或元素标识表

部件名称	有毒有害物质或元素					
	铅	汞	镉	六价铬	多溴联苯	多溴联苯醚
	Pb	Hg	Cd	Cr <sup>6+</sup>	PBB	PBDE
半导体器件类	×	○	○	○	○	○
开关/断路器类	○	○	×	○	○	○
陶瓷电子组件类	×	○	○	○	○	○
电源线和插座之端子	×	○	○	○	○	○
保险丝类	×	○	×	○	○	○
五金箱体类	×	○	○	○	○	○
蓄电池（适用时）	×	○	○	○	○	○
<p>○：表示该有毒有害物质在该部件所有均质材料中的含量在 SJ/T-11363—2006 规定的限量要求以下；</p> <p>×：表示该有毒有害物质至少在该部件的某一均质材料中的含量超出 SJ/T11363—2006 规定的限量要求</p> <p>艾默生网络能源有限公司一直致力于设计和制造环保的产品，我们会通过持续的研究来减少和消除产品中的有毒有害物质。以下部件或者应用中含有有毒有害物质是限于目前的技术水平无法实现可靠的替代或者没有成熟的解决方案：</p> <ol style="list-style-type: none"> <li>1. 半导体器件类的 CRT 和集成电路覆晶封装中含有铅。</li> <li>2. 开关/断路器/保险丝的触点含有镉及其镉化物。</li> <li>3. 陶瓷电子组件中含有铅。</li> <li>4. 电源线/插座端子/保险丝的铜合金中含有小于 4% 的铅，铝中含有小于 0.4% 的铅，钢中含有小于 0.35% 的铅。</li> <li>5. 五金箱体的铜合金中含有小于 4% 的铅，铝中含有小于 0.4% 的铅，钢中含有小于 0.35% 的铅。</li> <li>6. 蓄电池中含有铅是由产品特性和行业技术水平决定的</li> </ol> <p>关于环保使用期限的说明：本产品的环保使用期限（已标识在产品本体）是指在正常的使用条件和遵守本产品安全注意事项情况下，从生产日起本产品（蓄电池除外）含有的有毒有害物质或元素不会对环境、人身和财产造成严重影响</p> <p>适用范围：iTrust Adapt 1kVA~3kVA UPS</p>						

# Safety Precautions

This manual contains important safety instructions that must be followed during the installation and maintenance of the UPS and batteries. Read this manual thoroughly before attempting to install or operate this UPS.

## UPS Safety Notes

1. The UPS has no user-serviceable parts inside except the internal battery pack. Do not remove the cover, failure to observe this could result in electric shock risk and invalidation of any implied warranty.
2. The UPS has internal battery, therefore, the output receptacles of the UPS may carry live voltage even if the UPS is not connected to the AC mains.
3. Before moving or re-wiring the UPS, please disconnect the mains source and the associated battery, and make sure that the UPS is completely shut down. Or else, the output terminal may carry live voltage, thus presenting electric shock risk.
4. To ensure human safety and normal UPS operation, the UPS must be properly grounded before use.
5. When the UPS is applied in the IT power distribution system, the short-circuit protection device must be installed on the neutral line.
6. The operating environment affects the UPS lifetime and reliability. It is advisable not to use the UPS for long in the following environments:
  - Places where the temperature and relative humidity are outside the specifications (temperature: 0°C ~ 40°C, relative humidity: 0% ~ 95%)
  - Places in direct sunlight or near heat source
  - Places subject to vibrations or shocks
  - Dusty places, or places where corrosive substances, salts, or flammable gases are present
7. Please keep the air inlet and outlet of the UPS unobstructed. Poor ventilation will increase the UPS internal temperature, which will shorten the lifetime of the UPS components, hence that of the UPS.
8. Liquid and other irrelevant objects are strictly prohibited inside the UPS.
9. In case of fire, use dry chemical fire extinguisher to put out the fire. Using fluid fire extinguisher may cause electric shock.
10. The UPS output cable should be shorter than 10m.

## Battery Safety Notes

1. Do not open or damage the battery, as the battery electrolyte is harmful to human skin and eyes. If electrolyte comes into contact with the skin, wash the affected area with plenty of clean water immediately and go to the hospital for a check.
2. Never dispose of the battery in a fire, as it may explode and jeopardize personnel safety when exposed to flame.
3. A battery can present a risk of electrical shock and high short circuit current. Remove watches, rings, and other metal objects and use tools with insulated handles when working on batteries.
4. Do not short connect the battery terminals, or it may cause inflammation.

## Information for the Protection of the Environment

UPS Servicing: UPS makes use of components dangerous for the environment (electronic cards, electronic component. The components removed must be taken to specialized collection and disposal centers.)

UPS dismantling: in case of UPS dismantling, this operating shall be carried out by specialized personnel. UPS must be taken to centers specialized in collection and disposal of dangerous substance.



**Others**

1. The UPS is suitable for resistive-capacitive load (like computer), resistive load and micro-inductive load. It is not suitable for purely inductive load or purely capacitive load (like motor, air-conditioner and duplicator), nor can it be connected to half-wave rectifier load.

2. When the UPS is purchased to deliver power to the equipment listed below, please discuss with the manufacturer in advance about the applicability, setting, management and maintenance of the UPS, as these need special considerations during design.

- Life-supporting medical apparatus
- Facilities such as lifts where adequate care has to be taken to avoid any fatal eventuality endangering human life
- Any other mission-critical equipment like the above

# Contents

Chapter 1 Product Description .....	1
1.1 Features.....	1
1.2 Models .....	1
1.3 Appearance And Components.....	2
1.3.1 Appearance .....	2
1.3.2 Components .....	2
1.4 Operating Principle .....	3
1.5 Operating Mode .....	4
1.6 Specifications.....	5
Chapter 2 Installation .....	7
2.1 Unpacking Inspection.....	7
2.2 Installation Preliminaries .....	7
2.3 Mechanical Installation.....	7
2.3.1 Tower Installation .....	7
2.3.2 Rack Installation .....	9
2.4 Cable Connection .....	10
2.4.1 Connecting Input Plug And Loads .....	10
2.4.2 Connecting Battery Cables.....	11
2.4.3 Connecting Communication Cables .....	11
Chapter 3 Operation And Display Panel.....	12
3.1 Control Buttons .....	12
3.2 Indicators .....	13
3.2.1 Level Indicators .....	13
3.2.2 UPS State Indicators .....	14
Chapter 4 Operating Instruction .....	15
4.1 Check Before Turn-On.....	15
4.2 Turning On UPS.....	15
4.3 Manual Battery Test.....	15
4.4 Manual Bypass .....	15
4.5 Turning Off UPS.....	15
Chapter 5 Communication.....	17
5.1 SNMP Card Port.....	17
5.2 Dry Contact.....	17
5.2.1 Any Mode Shutdown .....	18
5.2.2 Battery Mode Shutdown .....	18

Chapter 6 Maintenance .....	19
6.1 Replacing Internal Battery Pack .....	19
6.2 Precautions .....	20
6.3 Checking UPS State .....	20
6.4 Checking UPS Functions .....	21
Chapter 7 Troubleshooting .....	23
7.1 UPS Symptoms .....	23
7.1.1 Indicators .....	23
7.1.2 Audible Alarm .....	23
7.2 Troubleshooting .....	24
Appendix 1 Battery Cabinet .....	26



# Chapter 1 Product Description

Thank you for your choice of iTrust Adapt 1kVA ~ 3kVA uninterruptible power system (UPS for short).

The UPS is a compact, on-line UPS which continuously conditions and regulates its output voltage, whether mains power is present or not. It supplies connected loads with clean sine wave power. It is applicable to supplying AC power to microcomputers and other sensitive electronic equipment.

This chapter gives a brief description of the UPS, including the UPS features, models, appearance and components, operating principle, operation mode and specifications.

## 1.1 Features

The UPS features include:

- Providing more efficient AC power, compared with the previous generation
- Full digital control technology based on digital signal processor (DSP) to achieve high system reliability with self-protection and fault diagnosis
- Intelligent battery management to extend the battery life
- Operation and display panel with LED indication, which can indicate both load percentage and battery capacity independently to help you learn about the system operation status and operating parameters.
- 2U thick. Tower installation and rack installation are optional to meet different installation requirements
- Fan fault self-inspection and automated diagnosing function
- Intelligent design for the fan. The fan rotating speed can be auto-conditioned according to the loads to decrease power consuming and noise
- More powerful overload capability. In the event of output overload, users only need to turn on the input circuit breaker to make the UPS recover operating instead of replacing fuse for the previous generation
- Five kinds of option cards, providing network communication function
- Capable of connecting up to four battery cabinets, extending the power supply time of battery mode, charging the battery more efficiently and consuming less time
- Providing a standard B-type USB port for communication between the UPS and a network server or other computer systems
- Providing dry contacts to realize remote shutdown function to facilitate operation
- Input power factor over 0.99 under the specified operating conditions, and verified under boundary conditions
- Output voltage selection function
- Lower input THDI and output THDU
- Providing more output receptacles to facilitate users to use the UPS

## 1.2 Models

As given in Table 1-1, seven models are available.

Table 1-1 Models

Model	Nominal power rating	Model	Nominal power rating
UHA1R-0010	1000VA/900W	UHA1R-0020L	2000VA/1800W
UHA1R-0010L	1000VA/900W	UHA1R-0030	3000VA/2700W
UHA1R-0015	1500VA/1350W	UHA1R-0030L	3000VA/2700W
UHA1R-0020	2000VA/1800W		

## 1.3 Appearance And Components

### 1.3.1 Appearance

The appearance of the UPS is shown in Figure 1-1.

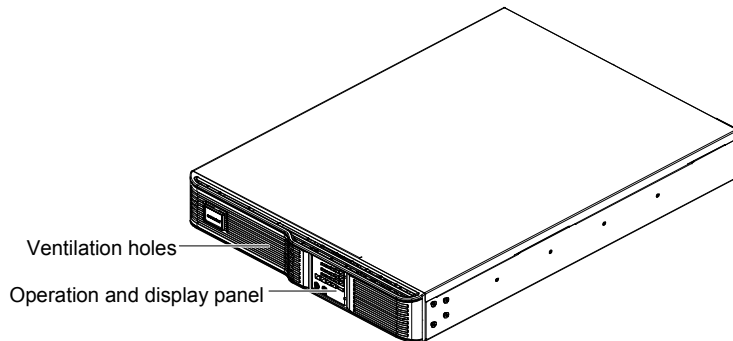

Figure 1-1 Appearance of the UPS

**Note**

Non-professionals are prohibited from opening the chassis cover. Failure to observe this could result in electric shock.

### 1.3.2 Components

#### Operation and display panel

The UPS provides an operation and display panel on the front panel, as shown in Figure 1-1. The operation and display panel provides LED indicators and control buttons. For details, refer to *Chapter 3 Operation And Display Panel*.

#### Rear panel

As shown in Figure 1-2, the rear panel of the UHA1R-0010, UHA1R-0010L, UHA1R-0015, UHA1R-0020 and UHA1R-0020L UPS provides the following components:

- |                                      |   |                          |
|--------------------------------------|---|--------------------------|
| A DIP switch (with protective cover) | An SNMP card port (with protective cover) | A USB port               |
| A dry contact                        | A cooling fan                             | An input circuit breaker |
| An external battery connector        | An input plug                             | A C13 output receptacle  |
| Three GB output receptacles          |   |                          |

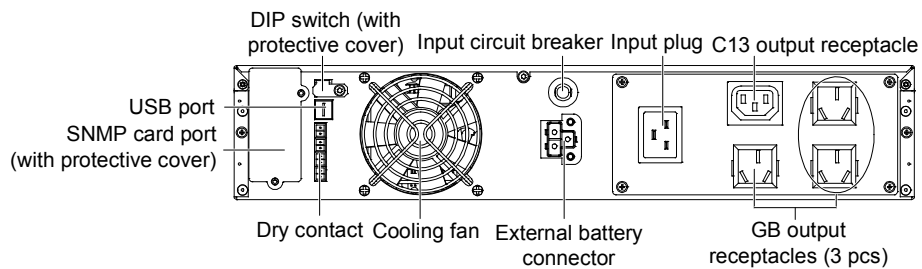

Figure 1-2 Rear panel of the UHA1R-0010, UHA1R-0010L, UHA1R-0015, UHA1R-0020 and UHA1R-0020L UPS

As shown in Figure 1-3, the rear panel of the UHA1R-0030 and UHA1R-0030L UPS provides the following components:

- |                                      |   |                          |
|--------------------------------------|---|--------------------------|
| A DIP switch (with protective cover) | An SNMP card port (with protective cover) | A USB port               |
| A dry contact                        | A cooling fan                             | An input circuit breaker |
| An external battery connector        | A GB output receptacle                    | A C13 output receptacle  |
| A terminal block                     | An input plug                             |                          |

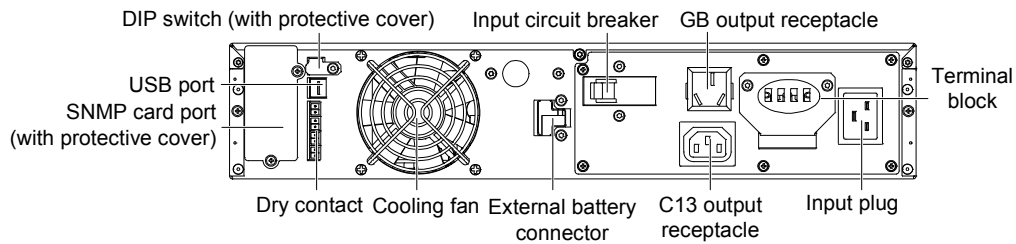

Figure 1-3 Rear panel of the UHA1R-0030 and UHA1R-0030L UPS

## 1.4 Operating Principle

The operating principle of the UPS is shown in Figure 1-4.

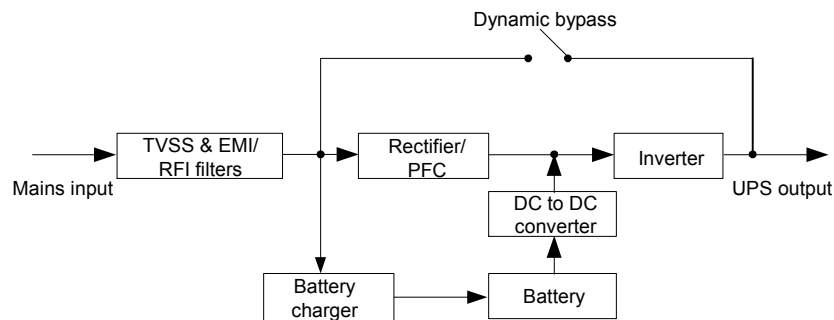

Figure 1-4 Operating principle diagram

The UPS is composed of mains input, TVSS & EMI/RFI filters, rectifier/PFC, inverter, battery charger, DC to DC converter, battery, dynamic bypass and UPS output.

### TVSS & EMI/RFI filters

The surge protection and filters of electromagnetic interference (EMI) and radio frequency interference (RFI) can minimize any surges or interference present in the mains line and keep the sensitive equipment protected. Meanwhile, the filters can also prevent surges or interference generated by the UPS from influencing other devices unprotected by the UPS.

### Rectifier/PFC

In normal operation, the rectifier/power factor correction (PFC) circuit converts mains AC power to regulated DC power for use by the inverter while ensuring that the waveshape of the input current used by the UPS is near ideal. Extracting this sine wave input current achieves two objectives:

- The mains power is used as efficiently as possible by the UPS.
- The amount of harmonic reflected on the mains is reduced.

The amount of harmonic generated by the rectifier is little, and the power supply is not polluted, so other devices in the building unprotected by the UPS will not be interfered.

### Inverter

In normal operation, the inverter utilizes the DC output of the PFC circuit and inverts it into precise, regulated sine wave AC power. Upon a mains power failure, the inverter receives its required energy from the battery through the DC to DC converter. In both modes of operation, the UPS inverter is on-line and continuously generating clean, precise, regulated AC output power.

### Battery charger

The battery charger utilizes energy from the mains power and precisely regulates it to continuously “float charge” the batteries. The batteries are being charged whenever the UPS is plugged in, even when the UPS is not turned on.

### DC to DC converter

The DC to DC converter utilizes energy from the battery and raises the DC voltage to the optimum operating voltage for the inverter. This allows the inverter to operate continuously at its optimum efficiency and voltage, thus increasing reliability.

**Battery**

The UPS utilizes valve-regulated, nonspillable, lead acid batteries. To maintain battery design life, operate the UPS in an ambient temperature of 32°F to 77°F (0°C to 25°C).

Optional external battery cabinets are available to extend battery run times.

**Dynamic bypass**

The UPS provides an alternate path for mains power to the connected loads in the unlikely event of a UPS malfunction. Should the UPS have an overload, overtemperature, or UPS failure condition, the UPS automatically transfers the connected loads to bypass.

---

 **Note**

The bypass power path does not protect the connected loads from disturbances on the mains supply.

---

## 1.5 Operating Mode

The UPS operation modes include: Mains (AC) mode, static bypass mode, battery mode, and battery recharge mode. For the descriptions of indicators and control buttons in this section, refer to *Chapter 3 Operation And Display Panel*.

**Mains (AC) mode**

During Mains (AC) Mode, mains power provides energy to the UPS. The filters, PFC circuit and the inverter process this power to provide high level power to connected loads. Meanwhile, the UPS maintains the batteries in a fully charged state.

**Static bypass mode**

Static Bypass mode occurs when the Standby/Manual bypass button is pressed once while the UPS is in Mains (AC) Mode. Bypass operation is indicated by an audible alarm and illuminated amber Bypass indicator (If other indicators are illuminated, please refer to *Chapter 7 Troubleshooting*). During static bypass mode, mains power provides energy to the UPS. The mains power bypasses the inverter and provides power for the connected loads.

---

 **Caution**

Turning off the UPS in static bypass mode will result in loss of output power.

---

**Battery mode**

Battery mode occurs in event of an extreme mains condition or complete mains failure. The battery system supplies power through the DC to DC converter to the inverter to generate clean AC power for the connected loads.

During battery mode an alarm sounds 0.5 second beep, re-occurring every ten seconds. This will change to 0.5 second beeps, re-occurring every five seconds when the battery runs low (approximately 2 minutes remaining, user configurable).

At this time, the AC Input indicator will extinguish, and the Battery level indicators will illuminate to warn that a mains problem has occurred. Each battery level indicator represents a 20% capacity level. As capacity decreases, fewer indicators remain illuminated. Refer to *Chapter 7 Troubleshooting*.

For approximate battery run times, refer to *Appendix 1 Battery Cabinet*. The times listed in Table 2 are approximate based on resistive load and an ambient temperature of 77°F (25°C). To increase this time, turn off non-essential loads (such as idle computers and monitors) or add optional external battery cabinets.

---

 **Caution**

1. Turning OFF the UPS in battery mode will result in loss of output power.
  2. If the UPS is manually turned OFF, it must be manually restarted after mains power is restored.
  3. If the UPS is turned OFF by a communication signal or because the batteries are depleted, it will operate as selected in the configuration program for Auto-Restart.
-



### Battery recharge mode

Once mains power is restored, the UPS resumes Mains (AC) Mode. At this time, the Battery Charger begins recharging.

#### Caution

AC input voltages may still exist even if the AC input indicator extinguishes. When the UPS is operating, please do not touch the AC input plug.

## 1.6 Specifications

The specifications of the UPS are listed in Table 1-2 and Table 1-3.

Table 1-2 Specifications of UHA1R-0010, UHA1R-0010L and UHA1R-0015 UPS

Parameters		Product model		
		UHA1R-0010	UHA1R-0010L	UHA1R-0015
Model rating		1000VA/900W	1000VA/900W	1500VA/1350W
Input AC	Voltage range (typical)	220Vac nominal; variable based on output load		
	100% loading	176Vac/280Vac		
	50% ~ 100% loading	120Vac ~ 176Vac, linear increase		
	Power factor	0.99		
	Frequency	40Hz ~ 70Hz; Auto Sensing		
	Input plug	IEC 320 C20		
Output AC	Output receptacles	C13 × 1 and 3 × 250Vac/10A GB output receptacles		
	Voltage	220/230/240Vac (user configurable); ±3%		
	Power factor	0.9		
	Frequency	50Hz or 60Hz; ±0.1Hz		
	Waveform	Sine wave		
	Mains (AC) mode overload	105% to 150% for 60s; 150% to 200% for 2s; >200% for 250ms with transfer to bypass		
Battery	Type	Valve-regulated, nonspillable, leadacid		
	Qty × V × Rating	4 × 12V × 5.0Ah	4 × 12V × 7.2Ah	
	Battery Mfg/Part#	YUASA/NPH5-12 CSB/ HR 1221W	Panasonic/UP-RW1236 CSB/ GP 1272	
	Back-Up time	Refer to <i>Appendix 1 Battery Cabinet</i>		
	Recharge time	3 Hours to 90% capacity after full discharge with 100% load till UPS auto-shutdown (Internal Batteries Only)		
Environmental	Operating temperature	+32°F to +104°F (0°C to +40°C); variable based on output load		
	Storage temperature	+5°F to +122°F (-15°C to +50°C)		
	Relative humidity	0%RH to 95%RH, non-condensing		
	Operating elevation	Up to 10,000 ft. (3000m) at 104°F (40°C) without derating		
	Storage elevation	50,000 ft. (15000m) maximum		
		Audible noise	< 46dB, at 1 meter from the rear; < 43dB, at 1 meter from the front or sides	< 50dB, at 1 meter from the rear; < 48dB, at 1 meter from the front or sides
Agency	Safety	CCEE (GB4943-1995) /GB4943		
	RFI/EMI	IEC/EN/AS 62040-2 2nd Ed =CISPR22 Class A		
	Surge immunity	IEC/EN-61000-4-5, endurance level 3 (2kV) (live line to earth), level 2 (1kV) (during live lines)		
Dimensions (D × W × H, mm)	Unit	500×430×85	500×430×85	500×430×85
	Shipping	647×607×270	647×607×270	647×607×270
Weight (kg)	Unit	20	9	22
	Shipping	24	13	26

Table 1-3 Specifications of UHA1R-0020, UHA1R-0020L, UHA1R-0030 and UHA1R-0030L UPS

Parameters		Product model			
		UHA1R-0020	UHA1R-0020L	UHA1R-0030	UHA1R-0030L
Model rating		2000VA/1800W	3000VA/2700W	3000VA/2700W	3000VA/2700W
Input AC	Voltage range (typical)	220Vac nominal; variable based on output load			
	100% loading	176Vac/280Vac			
	50% ~ 100% loading	120Vac ~ 176Vac, linear increase			
	Power factor	0.99			
	Frequency	40Hz ~ 70Hz; Auto Sensing			
	Input plug	IEC 320 C20			
Output AC	Output receptacles	C13 × 1 and 3 × 250Vac/10A GB output receptacles	C13 × 1, 1 × 250Vac/10A GB output receptacles and 1 × 250Vac/16A output terminal block		
	Voltage	220/230/240Vac (user configurable); ±3%			
	Power factor	0.9			
	Frequency	50Hz or 60Hz; ±0.1Hz			
	Waveform	Sine wave			
	Mains (AC) mode overload	105% to 150% for 60s; 150% to 200% for 2s; >200% for 250ms with transfer to bypass			
Battery	Type	Valve-regulated, nonspillable, lead acid			
	Qty × V × Rating	4 × 12V × 9.0Ah		6 × 12V × 9.0Ah	
	Battery Mfg/Part#	Panasonic/UP-RW1245 CSB/ HR 1234W F2			
	Back-Up time	Refer to <i>Appendix 1 Battery Cabinet</i>			
	Recharge time	3 Hours to 90% capacity after full discharge with 100% load till UPS auto-shutdown (Internal Batteries Only)			
Environmental	Operating temperature	+32°F to +104°F (0°C to +40°C); variable based on output load			
	Storage temperature	+5°F to +122°F (-15°C to +50°C)			
	Relative humidity	0%RH to 95%RH, non-condensing			
	Operating elevation	Up to 10,000 ft. (3000m) at 104°F (40°C) without derating			
	Storage elevation	50,000 ft. (15000m) maximum			
	Audible noise	< 48dB, at 1 meter from the rear; < 48dB, at 1 meter from the front or sides	< 50dB, at 1 meter from the rear; < 48dB, at 1 meter from the front or sides	< 48dB, at 1 meter from the rear; < 48dB, at 1 meter from the front or sides	< 50dB, at 1 meter from the rear; < 48dB, at 1 meter from the front or sides
Agency	Safety	CCEE (GB4943-1995) /GB4943			
	RFI/EMI	IEC/EN/AS 62040-2 2nd Ed =CISPR22 Class A			
	Surge immunity	IEC/EN-61000-4-5, endurance level 3 (2kV) (live line to earth), level 2 (1kV) (during live lines)			
Dimensions (D × W × H, mm)	Unit	500×430×85	500×430×85	600×430×85	600×430×85
	Shipping	647×607×270	647×607×270	747×607×270	747×607×270
Weight (kg)	Unit	24	10	28	12
	Shipping	28	14	32	16

## Chapter 2 Installation

This chapter expounds the UPS installation, including unpacking inspection, installation preliminaries, mechanical installation and cable connection.

### 2.1 Unpacking Inspection

Unpack the UPS and conduct the following checks:

1. Visually inspect the UPS appearance for shipping damage. If any shipping damage is founded, report it to the carrier and your local dealer immediately.
2. Check the accessories against the delivery list. If there is any discrepancy, contact the distributor immediately.

### 2.2 Installation Preliminaries

#### Installation environment

1. Do not install the UPS outdoors. The installation environment should meet the specifications (refer to 1.6 *Specifications*).
2. Install the UPS in an environment with good ventilation and free of dust, volatile gas, salt, and corrosive materials. Keep the UPS far away from water, heat source, flammables and explosive substances. Avoid direct sunlight.



#### Note

UPS operation in temperatures above 77°F (25°C) reduces battery life.

---

#### Installation clearances

Maintain a clearance of at least 200mm at front panel and back panel of the UPS. Keep the air inlets unobstructed on the front panel and rear panel of the UPS to facilitate ventilation and heat dissipation. Otherwise, the UPS internal temperature will rise, which will shorten the lifetime of the UPS.

### 2.3 Mechanical Installation

Two installation modes are available: tower installation and rack installation, depending on available space and use considerations. You can select an appropriate installation mode according to the actual conditions.

#### 2.3.1 Tower Installation



#### Note

Various installation configurations are available: single UPS, single UPS with single or multiple battery cabinets. Their installation methods are all the same.

---

The installation procedures are as follows:

Step 1: Take out the support bases from the accessories. Their appearances are shown in Figure 2-1.

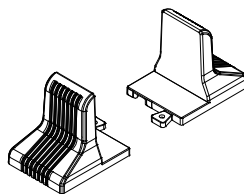

Figure 2-1 Support bases

Step 2: If optional external battery cabinets are connected to the UPS to provide additional battery run time, take out the spacers delivered with the battery cabinet, and then assemble the spacers and the support bases through fastenings, as shown in Figure 2-2.

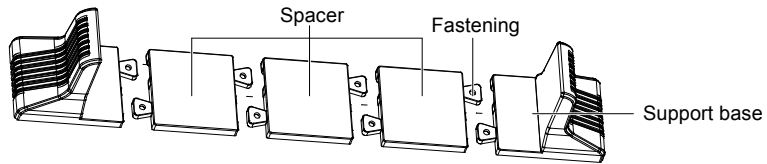

Figure 2-2 Installing support bases with spacers

**Note**

Up to four external battery cabinets can be used but each cabinet will increase the battery recharge time.

Step 3: Adjust the direction of UPS operation and display panel and LOGO.

1. Remove the front plastic bezel cover gently, as shown in Figure 2-3.

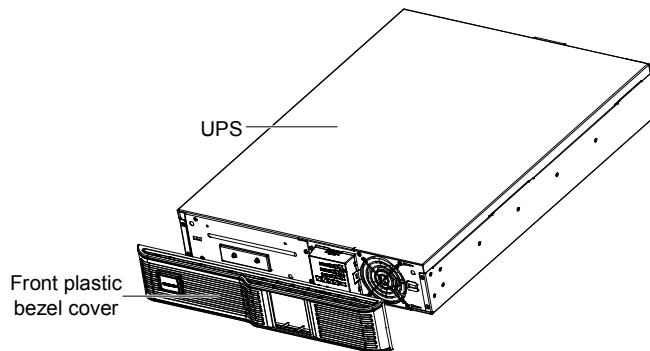

Figure 2-3 Removing the front plastic bezel cover

2. Pull the operation and display panel gently, rotate it 90 degrees clockwise and snap it back into position, as shown in Figure 2-4.

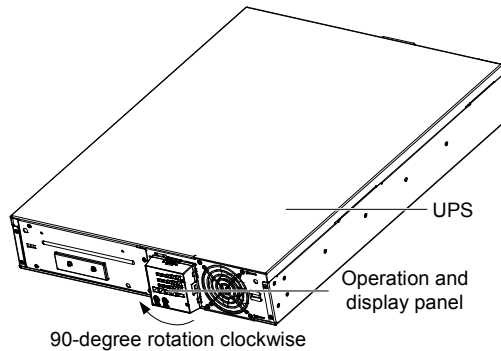

Figure 2-4 Rotating the operation and display panel

3. Pull the LOGO on the front plastic bezel cover gently, rotate it 90 degrees clockwise and snap it back into position. After rotation, the front plastic bezel cover is shown in Figure 2-5.

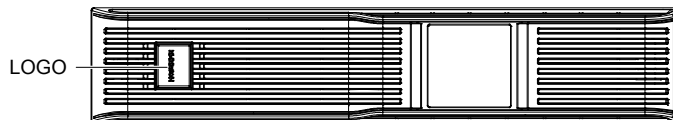

Figure 2-5 The rotation of LOGO is completed

4. Restore the front plastic bezel cover to the UPS. At this point, the UPS operation and display panel and LOGO have been rotated 90 degrees clockwise, which provides upright viewing for users.

Step 4: Place the UPS (and battery cabinet) on the support bases. Each UPS needs two pairs of support bases to install, as shown in Figure 2-6.

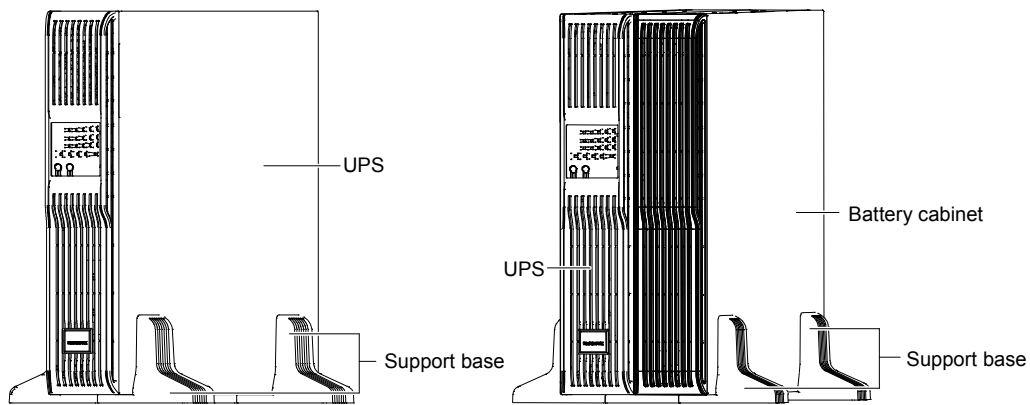

Figure 2-6 Tower installation

---

**Note**

Place the two pairs of support bases as far away as possible to avoid tipping the UPS. It is recommended to keep a distance of 70mm from the UPS front and rear panel to the corresponding support bases.

---

### 2.3.2 Rack Installation

---

**Note**

1. Various installation configurations are available: single UPS, single UPS with single or multiple-battery. Their installation methods are all the same.
  2. Because battery cabinets are too heavy, they must be installed first, and two or more installation personnel are required to install them at the same time. Please install them from bottom to top.
- 

Rack installation: fix the UPS and battery cabinet onto the rack through brackets.

Installation method:

1. Take out two brackets and eight M4 × 10 screws from the accessories, and fix the brackets onto the battery cabinet using the screws through installation hole1, as shown in Figure 2-7.

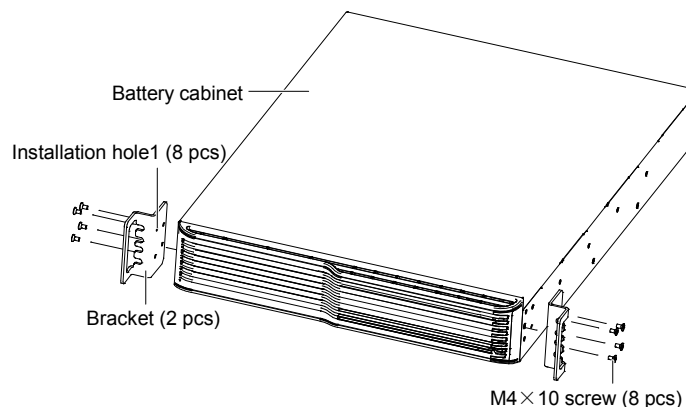

Figure 2-7 Installing brackets

2. Place the battery cabinet onto the guide rail in the rack, and push it completely into the rack along the guide rail (it is prohibited to move the battery cabinet through the brackets). Take out four M6 × 16 screws from the accessories, and fix the battery cabinet onto the rack using the screws through installation hole2 on the bracket, as shown in Figure 2-8.

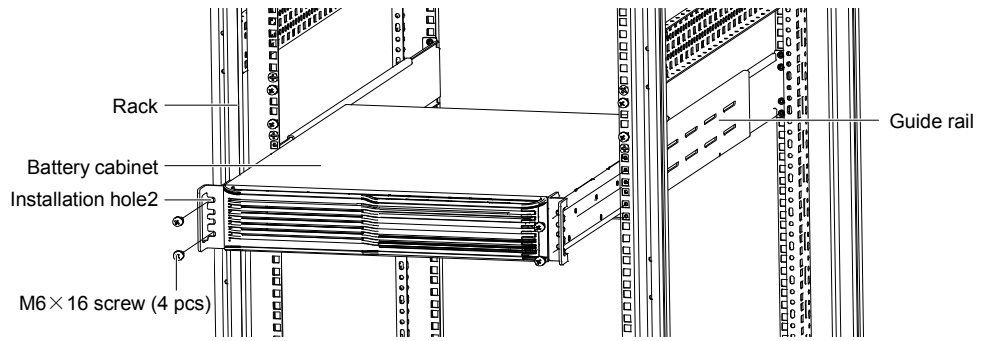

Figure 2-8 Installing battery cabinet

3. The installation method of the UPS is the same as that of the battery cabinet. Install the UPS on top of the battery cabinet. The rack installation method of single standard UPS and single battery cabinet is shown in Figure 2-9.

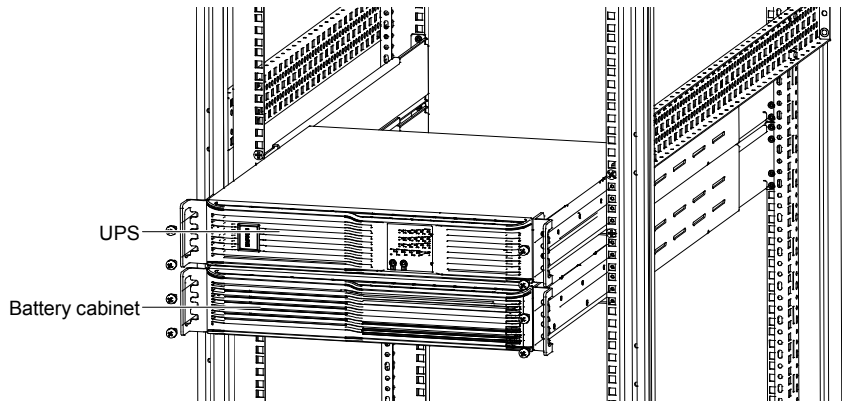

Figure 2-9 Rack installation of single standard UPS and single battery cabinet

## 2.4 Cable Connection

The UPS rear panel provides input plug, output receptacles, input cable and output cable(s). Refer to 1.3.2 *Components* for details. The battery cables are delivered with the battery cabinet.

### 2.4.1 Connecting Input Plug And Loads

#### Notes

1. Ensure that all the loads are turned off.
2. Prepare a wall receptacle as input power which is properly protected by a circuit breaker in accordance with national and local electrical codes. The wall receptacle must be grounded.
3. It is recommended to choose an upstream circuit breaker of the same series as the UPS input circuit breaker and the upstream breaker should be larger than the UPS input circuit breaker.

The specification of input circuit breaker on the rear panel of UPS is given in Table 2-1.

Table 2-1 Specification of input circuit breaker

Model	Rated circuit breaker	Model	Rated circuit breaker
UHA1R-0010	10A	UHA1R-0020L	16A
UHA1R-0010L	10A	UHA1R-0030	25A
UHA1R-0015	10A	UHA1R-0030L	25A
UHA1R-0020	16A		

#### Connecting procedures

1. Plug all loads into the output receptacles on the rear panel of the UPS.

#### Note

It is recommended not to overload single output receptacle.

2. Plug the input plug of UPS into the wall receptacle.

## 2.4.2 Connecting Battery Cables



### Note

The battery cabinet comprises batteries of the same manufacturer, same model, and same use state.

---

### Connection procedures

1. Cut off the input breaker of the battery cabinet.
2. Take out the battery cable delivered with the battery cabinet, connect one end of the battery cable to the external battery connector on the rear panel of the UPS, and connect the other end to any battery port on the rear panel of the battery cabinet.
3. Turn on the battery breaker on the rear of the external battery cabinet.
4. Use the included Configuration Program to specify the number of external battery cabinets connected to the UPS. For approximate battery run times, refer to *Appendix 1 Battery Cabinet*.



### Note

If the number of external battery cabinets is not specified, UPS may generate an alarm.

---

## 2.4.3 Connecting Communication Cables

Communication cable connection includes: connecting USB communication cable and connecting option card communication cable.

### Connecting USB communication cable

1. Take out the USB communication cable from the accessories.
2. Insert one end of the USB communication cable to the USB port on the rear panel of the UPS (see Figure 1-2 and Figure 1-3).
3. Insert the other end of the USB communication cable to the USB port of the computer.

### Connecting option card communication cable

The procedures of option card installation and communication cable connection are as follows:

1. Remove the protective cover of the SNMP card port, and take good care of it for future use.
2. Insert the option card into the SNMP card port and fasten it with screws.
3. Connect the UPS to computer network port with a network cable (prepared by users).
4. For the setting and use of the option card, refer to User Manual of the option card.

## Chapter 3 Operation And Display Panel

This chapter introduces the control buttons and indicators of the operation and display panel.

The operation and display panel is located on the front panel of the UPS (see Figure 1-1), which provides two control buttons and seven kinds of indicators, as shown in Figure 3-1.

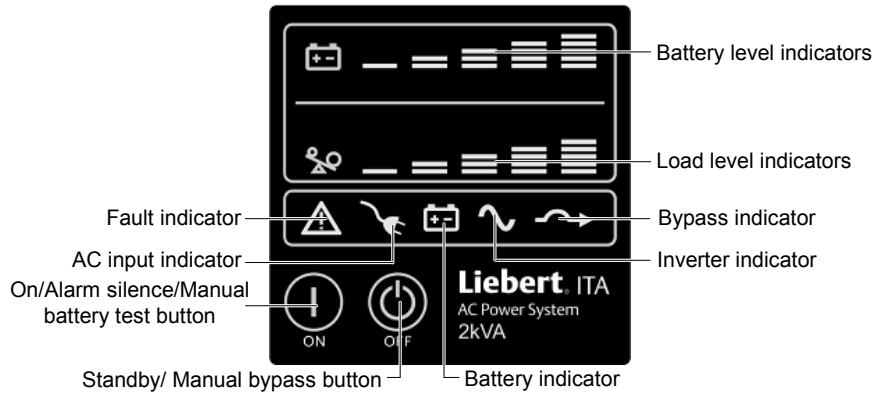

Figure 3-1 Operation and display panel

### 3.1 Control Buttons

The operation and display panel provides two control buttons: On/Alarm silence/Manual battery test button and Standby/Manual bypass button.

#### On/Alarm silence/Manual battery test button

The On/Alarm silence/Manual battery test button controls output power to connected load(s) and has three functions, as given in Table 3-1.

Table 3-1 Functions of On/Alarm silence/Manual battery test button

Function	Operation	Description
ON	Press the button once for three seconds	To start up the UPS
Alarm silence <sup>1</sup>	Press the button for at least 0.5 second	To silence alarms <sup>2</sup>
Manual battery test	Press the button for at least 0.5 second while operating in mains (AC) mode with no alarm conditions present.	To initiate a manual battery test
Note: 1. The low battery and bypass reminder alarms cannot be silenced. 2. After the alarm is silenced, UPS will reactivate the alarm system to alert of a new alarm		

#### Standby/Manual bypass button

The Standby/Manual bypass button controls output power to connected load(s) and has dual functions as given in Table 3-2.

Table 3-2 Functions of On/Alarm silence/Manual battery test button

Function	Operation	Description
Standby	Press the button twice within four seconds <sup>1</sup>	To shutdown the UPS and remove all power to the connected loads
Manual bypass	Press the button once <sup>2</sup>	To initiate a manual transfer of the connected loads to the internal bypass if available
Note: 1. Perform all necessary shutdown procedures on connected loads before turning off the UPS. 2. If the bypass is not available due to voltage or frequency, pressing this button once will be ignored		



## 3.2 Indicators







The operation and display panel provides seven kinds of indicators (see their positions in Figure 3-1), which can be divided into two groups according to the applications: level indicators and UPS state indicators.

### 3.2.1 Level Indicators

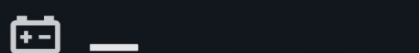
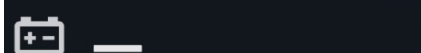
#### Battery level indicators

The battery level indicators include five segments composed of LED bars which are used to indicate the battery capacity level. The UPS battery capacity level will be indicated in 20% increments ( $\pm 5\%$ ) and the states of the battery level indicators are listed in Table 3-3.

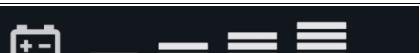
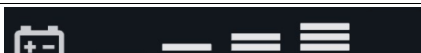



Table 3-3 Battery level indicators

Battery level	Indicators state	
	Charging	Discharging
0~20%	 Flash OFF OFF OFF OFF	 On OFF OFF OFF OFF
21%~40%	 On Flash OFF OFF OFF	 On On OFF OFF OFF
41%~60%	 On On Flash OFF OFF	 On On On OFF OFF
61%~80%	 On On On Flash OFF	 On On On On OFF
81%~100%	 On On On On Flash	 On On On On On

#### Load level indicators

The load level indicators include five segments composed of LED bars which are used to indicate the relative load on the UPS output. The load level on the UPS output will be indicated in 25% increments ( $\pm 5\%$ ) and the states of the load level indicators are listed in Table 3-4.





Table 3-4 Load level indicators

Load level	Indicators state	Load level	Indicators state
0 ~ 25%	 On OFF OFF OFF OFF	26% ~ 50%	 On On OFF OFF OFF
51% ~ 75%	 On On On OFF OFF	76% ~ 100%	 On On On On OFF
> 100%	 On On On On On		

### 3.2.2 UPS State Indicators

UPS state indicators include five indicators: fault indicator, AC input indicator, battery indicator, inverter indicator and bypass indicator. Their descriptions are listed in Table 3-5.

Table 3-5 UPS state indicators

UPS state indicator	Icon	Color	Description
Fault indicator		Red	On if the UPS has detected a fault, and off otherwise
AC input indicator		Green	On when the mains AC is normal, off when mains AC fails or mains AC voltage is outside specifications
Battery indicator		Amber	On when the battery is supplying power, and off otherwise
Inverter indicator		Green	On when the inverter is supplying power, and off otherwise
Bypass indicator		Amber	On when the bypass is supplying power, off otherwise, and flashes when mains AC voltage is outside specifications

## Chapter 4 Operating Instruction

This chapter describes UPS check before turn-on, turning on UPS, manual battery test, manual bypass, and turning off UPS.

---

 **Note**

The battery has been fully charged before delivery. However, storage and transportation will inevitably cause some charge loss. Therefore, it is required to charge the battery for three hours before putting the UPS into operation, so as to ensure adequate battery autonomy.

---

### 4.1 Check Before Turn-On

Before turn-on, check the following:

1. Check that the input plugs and loads are connected properly and reliably.
2. Check that the battery cable is connected properly.
3. Check that the communication cables are connected properly.

### 4.2 Turning On UPS

1. Close the input circuit breaker (see Figure 1-2 and Figure 1-3 for its position).
2. Turn on the UPS by pressing the On/Alarm silence/Manual battery test button for three seconds.
3. Turn on the connected loads.

The UPS is now providing conditioned power to the loads.

### 4.3 Manual Battery Test

To initiate a manual battery test, press the On/Alarm silence/Manual battery test button for at least 0.5 second while operating from mains power with no alarm conditions present.

- If only first two of the five LED segments illuminate, allow the UPS to recharge the batteries for 24 hours
- After 24 hours, retest the batteries
- After the batteries have been retested, if only two of the five Battery LEDs illuminate, contact your local dealer
- If battery test fails after initiating a manual battery test, please check the battery connection and allow the UPS to recharge the batteries for 1 hour and initiate a manual battery test again
- If battery test fails for a second time, please replace batteries and contact your local dealer

### 4.4 Manual Bypass

Press the Standby/Manual bypass button once while the UPS is in mains (AC) mode, the UPS will transfer the connected loads to the internal bypass. If the internal bypass is not available due to voltage or frequency, pressing this button once will be ignored. Bypass operation is indicated by an audible alarm and illuminated amber Bypass indicator (If other indicators are illuminated, please refer to *Chapter 7 Troubleshooting*).

---

 **Note**

The overload in bypass mode is determined by current overload instead of power overload.

---

### 4.5 Turning Off UPS

1. Press the Standby/Manual bypass button twice within four seconds to turn off the UPS, all loads are powered off.

2. Disconnect input cable plug after turning off the UPS. 30s later, all indicators will turn off, and the fan will stop.
3. Place the external switch to OFF position if the UPS has an external battery cabinet.

At this point, the UPS ceases output and the loads are powered off.

## Chapter 5 Communication

The UPS is equipped with an SNMP card port, a standard B-type USB port and four pairs of dry contacts on the rear panel to provide advanced communication and monitoring options.

This chapter describes UPS communication by means of the SNMP card port and dry contacts.

### Caution

To maintain safety (SELV) barriers and for electromagnetic compatibility, signal cables should be segregated and run separate from all other power cables, where applicable.

## 5.1 SNMP Card Port

The SNMP card port is applicable for five option cards. See Table 5-1 for detailed information.

Table 5-1 Option cards

Option card	Function
UF-RS485 card	Transferring signals between RS232 and RS485
Dry contact extended card used in UF-DRY320 5k UPS	Providing four digital signal outputs by relay, three digital signal inputs and four routes analog signal acquiring function remotely
Dry contact card used in UF-DRY310 UPS	Providing four digital signal outputs by relay remotely
SNMP card used in Intellislot UPS	Communicating with the UPS through USB to acquire the UPS information; through the USB port setting, providing network port for the host to access through network
MODBUS card used in Liebert NX UPS	Selected and used according to company's unified planning. Acquiring the UPS information through communication between the USB and UPS with MODBUS protocol

The five cards provide functions of configuration program, monitoring the UPS and output voltage selection, refer to the user manual of each card for details.

## 5.2 Dry Contact

The dry contact includes eight pins, as shown in Figure 5-1. Their definitions are listed in Table 5-2.

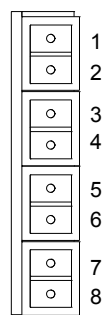

Figure 5-1 Dry contacts

Table 5-2 Pin definitions

Pin	Silk print	Definition
1 & 2	1, 2	Any mode shutdown
3 & 4	3, 4	Battery mode shutdown
5 & 6	5, 6	Battery low mode
7 & 8	7, 8	On battery mode

### 5.2.1 Any Mode Shutdown

The purpose of any mode shutdown is to shut down the UPS output by turning off rectifier, inverter & static switch so that there is no power to the loads.

Any mode shutdown can be operated locally and remotely, as described as follows:

- Local any mode shutdown can be operated by short connecting Pin1 & Pin2 with jumper cap
- Remote any mode shutdown can be operated by a switch connected to Pin1 & Pin2 and mounted at remote location

The actuation of the any mode shutdown will be logged as an event in the event history log.

**Note**

1. Remote shutdown will be performed either by NO or NC contact of any mode shutdown.
2. The current limited source (+12Vdc, 50mA) will be available from UPS.
3. The connection to UPS for remote connection will be via terminal block connector.
4. Any mode shutdown wiring will follow local wiring codes & laws.

---

 **Warning**

When Auto-enable output option is selected and the UPS output is disabled using Pin1&Pin2, the UPS output can turn on automatically and without warning if the Pin1&Pin2 connection is changed.

---

### 5.2.2 Battery Mode Shutdown

The purpose of the battery mode shutdown is to shut down the UPS by turning off rectifier, inverter & static switch so that there is no power to the load when the UPS is operating from Battery only.

Battery mode shutdown can be operated locally and remotely, as described as follows:

- Local any mode shutdown can be operated by short connecting Pin3 & Pin4 with jumper cap
- Remote any mode shutdown can be operated by a switch connected to Pin3 & Pin4 and mounted at remote location

The actuation of the battery mode shutdown will be logged as an event in the event history log.

**Note**

1. Remote shutdown will be performed by NO contact.
2. The current limited source (+12Vdc, 50mA) will be available from UPS.
3. The connection to UPS for remote connection will be via terminal block connector.
4. Battery mode shutdown wiring will follow local wiring codes & laws.
5. This signal must last for 1.5 seconds or longer.
6. A battery shutdown signal will not cause an immediate shutdown. It will start a 2 minute shut down timer. This timer cannot be stopped once triggered. If the mains returns during this count down the UPS will still shutdown and must remain shut down for 10 seconds. Whether the UPS turns back on when the power is restored depends on the auto-restart setting.

## Chapter 6 Maintenance

This chapter describes replacing internal battery pack, precautions, checking UPS state and checking UPS functions.

### 6.1 Replacing Internal Battery Pack

The UPS is designed to allow the user to safely replace the internal battery pack. Read the safety cautions before proceeding. Contact your local dealer to obtain the part number and pricing of the appropriate replacement battery pack.

#### Charge the batteries

The batteries are valve-regulated, nonspilling, lead acid and should be kept charged to obtain their designed life. The UPS continuously charges the batteries when connected to the mains supply.

When storing the UPS for any length of time, it is recommended to plug the UPS for at least 24 hours every four to six months to ensure full recharge of the batteries.

#### Safety precautions

The battery can present a risk of electrical shock and high short circuit current. The following precautions should be observed before replacing the battery pack:

- Remove rings, watches, or other metal objects.
- Wear rubber gloves and boots.
- Use tools with insulated handles.
- Do not lay tools or other metal objects on top of the batteries.
- If the battery replacement kit is damaged in any way or shows signs of leakage, contact your local dealer immediately.
- Do not dispose of batteries in a fire. The batteries may explode.
- Handle, transport and recycle batteries in accordance with local regulations.

#### Battery replacement procedures

Step 1: Gently remove the front plastic bezel cover from the UPS.

Step 2: Loosen and remove the six screws on the battery door, as shown in Figure 6-1. Lay the battery door aside for reassembly.

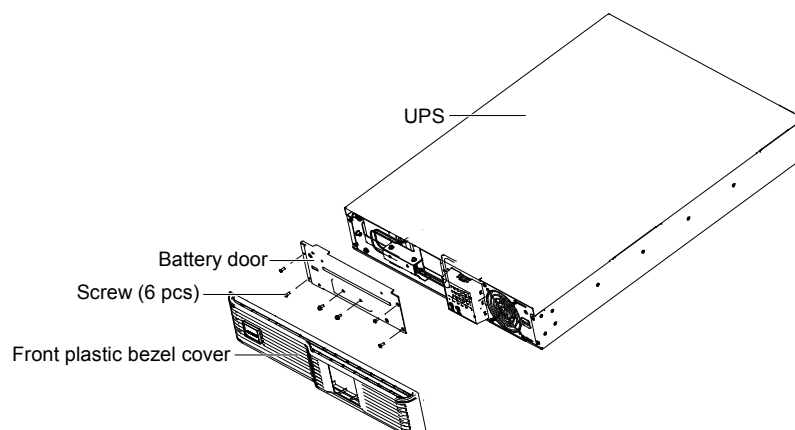

Figure 6-1 Removing the front plastic bezel cover and battery door

Step 3: Gently pull the battery wire out and disconnect the battery plug and the battery receptacle, as shown in Figure 6-2.

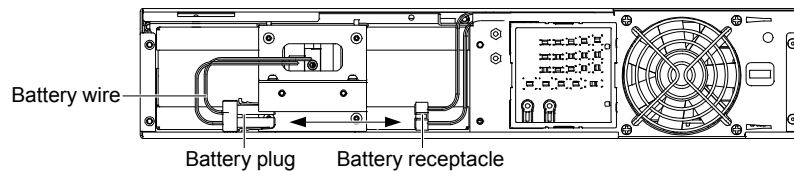

Figure 6-2 Disconnecting the battery plug and battery receptacle (front view)

Step 4: Grasp the battery handle, and pull the internal battery pack out of the UPS, as shown in Figure 6-3.

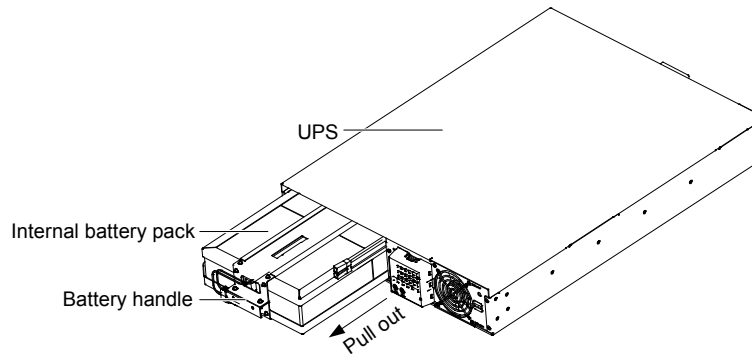

Figure 6-3 Pulling out the internal battery pack

Step 5: Unpack the new internal battery pack. Take care not to destroy the packing.

Compare the new and old internal battery pack to make sure they are the same. If so, proceed with Step 6; otherwise stop operation and contact your local dealer.

Step 6: Line up and slide in the new internal battery pack.

Step 7: Reconnect the battery plug and battery receptacle, and gently push the battery wire and internal battery pack back into the UPS.

Step 8: Reattach the front battery door with the six screws.

Step 9: Reattach the front plastic bezel cover to the UPS.

---

**Note**

1. It is strictly prohibited to hot plug the internal battery pack.
  2. Do not replace the internal battery pack while the UPS is operating in Battery Mode. This will result in a loss of output power and will drop the connected load. Moreover, it will jeopardize personnel safety!
- 

## 6.2 Precautions

Although the UPS has been designed and manufactured to ensure personal safety, improper use can result in electrical shock or fire. To ensure safety, observe the following precautions:

- Turn off the UPS before cleaning it.
- Clean the UPS with a dry cloth. Do not use liquid or aerosol cleaners
- Never block or insert any objects into the ventilation holes or other openings of the UPS
- Do not place UPS power cord anywhere it might be damaged

## 6.3 Checking UPS State

It is recommended to check the UPS operation status once every half year.

1. Check if the UPS is faulty: Is the FAULT indicator on? Is the UPS giving any alarm?
2. Check if the UPS is operating in Bypass mode: Normally, the UPS operates in Normal mode; if it is operating in Bypass mode, find out the reason, for instance: operator intervention, overload, internal fault, and so on.



3. Check if the battery is discharging: When the AC mains is normal, the battery should not discharge; if the UPS is operating in Battery mode, find out the reason, for instance: is it because of mains failure, battery test, operator intervention, and so on.

## 6.4 Checking UPS Functions

---

 **Note**

UPS function check operation may cause power interruption to load!

---

It is recommended to check the UPS functions once every half year.

Backup the load data, before conducting the UPS functions check. Procedures are as follows:

1. Press the Standby/Manual bypass button to check if the buzzer and indicators are normal.
2. Press the On/Alarm silence/Manual battery test button to check again whether the indicators are on and the UPS is running normally.
3. Press the On/Alarm silence/Manual battery test button for three seconds after Inverter mode, the UPS should initiate battery self-test. Check if the battery is normal. If not, find out the problem and solve it.



## Chapter 7 Troubleshooting

The chapter indicates various UPS symptoms a user may encounter and troubleshooting in the event the UPS develops a problem. Use the following information to determine whether external factors caused the problem and how to remedy the situation.

### 7.1 UPS Symptoms

The following symptoms indicate the UPS has malfunctions.

1. The relative indicators will illuminate, indicating the UPS detected a problem.
2. An alarm buzzer will sound, alerting that the UPS requires attention.

#### 7.1.1 Indicators

In addition to the fault indicator being illuminated, one or more of LED segments of battery level indicator will also be illuminated to provide a diagnostic aid to the user, as shown in Figure 7-1. The descriptions are listed in Table 7-1.



Figure 7-1 Battery level indicator

Table 7-1 Indicator descriptions

Indicator	Status	Diagnosis/Audible alarm
A ~ E	On	On bypass due to output overload (0.5 second beep, re-occurring every 0.5 seconds)
Fault Indicator	On (red)	
A	On	On bypass due to over temperature condition (1 second beep, re-occurring every four seconds)
Fault Indicator	On (red)	
B	On	On bypass due to DC bus overvoltage (1 second beep, re-occurring every four seconds) or output short circuit when the bypass frequency is abnormal
Fault Indicator	On (red)	
C	On	On bypass due to DC/DC power supply failure (1 second beep, re-occurring every four seconds)
Fault Indicator	On (red)	
D	On	PFC failure (1 second beep, re-occurring every four seconds)
Fault Indicator	On (red)	
E	On	On bypass due to inverter failure (1 second beep, re-occurring every four seconds)
Fault Indicator	On (red)	
A&C	On	UPS failed battery test (2 second beep, re-occurring every sixty seconds)
Fault Indicator	On (red)	
C&E	On	UPS shutdown due to command from communication (USB port or SNMP card port) (no audible)
Fault Indicator	On (red)	
A&B	On	UPS Failure(Includes Dual Fan failure, single fan failure under certain condition and Battery Charger Failure) and continuous audible alarm
Fault Indicator	On (red)	
Battery Indicator	Flashing	Internal Battery source not available (continuous horn). Check battery connection, completely turn off and reboot UPS
AC input indicator	Flashing	Line-to-neutral reversal in the AC input power supply or a loss of proper grounding for UPS; continuous horn and UPS cannot start up in standby status
Bypass indicator	Flashing	Mains power voltage or frequency is out of tolerance; bypass is unavailable
Note: A ~ E indicators are shown in Figure 7-1		

#### 7.1.2 Audible Alarm

An audible alarm will be used in conjunction with the visual indicators to indicate to the user a change in UPS operating status. The audible alarm will enunciate as given in Table 7-2.

Table 7-2 Audible alarm description

No.	Condition	Alarm
1	Battery discharge	0.5 second beep, re-occurring every ten seconds
2	Low battery	(2) 0.5 second beeps, re-occurring every five seconds
3	UPS fault, load on bypass	1 second beep, re-occurring every four seconds
4	UPS fault, no power to load	Continuous
5	Overload	0.5 second beep, re-occurring every 0.5 seconds
6	Battery replacement	2 second beep, re-occurring every sixty (60) seconds
7	Battery loss	Continuous
8	Wiring problem (including line-to-neutral reversal or a loss of proper grounding for UPS )	Continuous
9	Bypass reminder	1 second beep re-occurring every 2 minutes

## 7.2 Troubleshooting

In the event of a UPS fault, shoot the trouble in the first instance following the instructions provides in Table 7-3. If the fault persists, please contact 4008876510 for technical assistant.

Table 7-3 Troubleshooting table

No.	Problem	Cause	Solution
1	UPS fails to start when the On/Alarm silence/Manual battery test button is pressed	UPS is short circuited or overloaded	Ensure UPS is OFF. Disconnect all loads and ensure nothing is lodged in output receptacles. Ensure loads are not defective or shorted internally
2	Battery indicator is illuminated	UPS not plugged in	UPS is operating from battery mode, ensure UPS is securely plugged into the wall receptacle
		UPS input protection fuse has blown/opened	UPS is operating from battery mode. Save data and close applications. Replace UPS input fuse, then restart UPS
		Mains voltage out of UPS input range	UPS is operating from battery mode. Save data and close applications. Ensure mains supply voltage is within acceptable limits for UPS
3	UPS has reduced battery backup time	Batteries are not fully charged	Keep UPS plugged in continuously at least 24 hours to recharge batteries
		UPS is overloaded	Check load level indicator and reduce the load on the UPS
		Batteries may not be able to hold a full charge due to age	Replace batteries. Contact your local dealer for replacement battery kit
4	Fault and Bypass indicators and all LED segments of battery level indicator are illuminated	UPS overloaded or load is faulty	Check load level indicator and remove non-essential loads. Recalculate the load and reduce number of loads connected to UPS. Check load for faults
5	Fault and Bypass indicators and diagnostic A indicator are illuminated	UPS shutdown due to temperature condition. Load is on bypass power	Ensure UPS is not overloaded, ventilation holes not blocked, or room ambient temperature is not excessive. Wait 30 minutes to allow UPS to cool, then restart UPS. If UPS cannot restart, contact your local dealer
6	Fault and Bypass indicators and diagnostic B indicator are illuminated	UPS internal DC bus overvoltage (If the bypass indicator flashes, it is due to output short circuit when the bypass frequency is abnormal.)	Ensure that the load is not shorted, if not, the UPS requires service. Contact your local dealer
7	Fault and Bypass indicators and diagnostic C indicator are illuminated	UPS DC/DC fault	UPS requires service. Contact your local dealer
8	Fault indicator and diagnostic D indicator are illuminated	UPS PFC (Power Factor Correction Circuit) fault	UPS requires service. Contact your local dealer

No.	Problem	Cause	Solution
9	Fault and Bypass indicators and diagnostic E indicator are illuminated	UPS inverter fault	UPS requires service. Contact your local dealer
10	Fault indicator and diagnostic A and C indicators are illuminated	UPS failed the battery test	Replace batteries. Contact your local dealer
11	Fault and Bypass indicators and diagnostic C and E indicators are illuminated	UPS shutdown due to a command from the communications port(s)	Your UPS has received a signal or command from the attached computer. If this was inadvertent, ensure the communication cable used is correct for your system. For assistance, contact your local dealer
12	Fault indicator and diagnostic A and B indicators are illuminated	UPS Failure (Includes Dual Fan failure, single fan failure under certain condition and Battery Charger Failure) and continuous alarm	Ensure fan is not blocked up. If the fault is not removed, contact your local dealer
13	AC input indicator is flashing	UPS detected a line-to-neutral reversal or a loss of proper grounding for UPS; continuous horn and UPS cannot start up in standby status. This is active only when power is first applied to the input. Once the UPS is running, the AC input indicator will flash, unless the input wiring is correctly changed	Contact a qualified electrician to verify site wiring
14	Battery indicator is flashing	Battery source is not available; continuous horn	Check battery connections, completely turn off and restart the UPS. NOTE: If the battery circuit opens while the UPS is running, it will be detected when the next battery test is performed
15	Bypass indicator is flashing	Because the voltage or frequency is outside acceptable limits, the bypass is disabled	The AC input powers the PFC input and serves as the bypass source. If the AC is present but the voltage or frequency exceeds the acceptable range for safe operation with a load, the bypass will be disabled and this indicator will flash, indicating that the bypass is unavailable
Note: A ~ E indicators are shown in Figure 7-1			

When reporting UPS fault to Emerson or dealer, please inform the UPS model and machine No. (the bar code on the rear panel of the UPS).

## Appendix 1 Battery Cabinet

### Appearance

The UPS has optional battery cabinets. The battery cabinet provides battery port and input breaker on the rear panel, as shown in Figure 1.

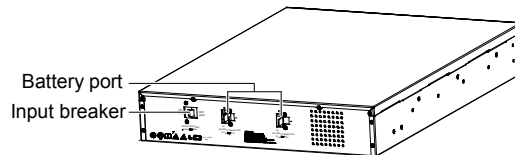

Figure 1 Battery cabinet

### Note

1. Because battery loop and AC input are not insulated, a dangerous voltage may exist between the battery ports and ground, it is prohibited to contact them.
2. The length of the standard battery cable delivered with the battery cabinet is 0.65m. If user needs cables of different length, please consult the dealer.

### Battery cabinet specifications

Table 1 Battery cabinet specifications

Parameter		Model Number	
		Adapt-72VBATT	Adapt-48VBATT
Used w/UPS Model		UHA1R-0030, UHA1R-0030L	UHA1R-0020, UHA1R-0020L, UHA1R-0015, UHA1R-0010, UHA1R-0010L
Dimensions (D × W × H, mm)	Unit	600 × 430 × 85	500 × 430 × 85
	Shipping	735 × 595 × 250	635 × 595 × 250
Weight (kg)	Unit	38	26
	Shipping	42	28
Battery parameters	Type	Valve-regulated, nonspilling, lead acid	
	Qty × V × Rating	2 × 6 × 12V × 9.0Ah	2 × 4 × 12V × 9.0Ah
	Battery Mfg/Part#	Panasonic/UP-RW1245 CSB/HR 1234W F2	Panasonic/UP-RW1245 CSB/HR 1234W F2
	Back-Up Time	See Table 2 Battery Run Time	
Environmental	Operating Temp	+32°F to + 104°F (0°C to +40°C)	
	Storage Temp	+19°F to + 104°F (-15°C to +40°C)	
	Relative Humidity	0% to 95%, non-condensing	
	Operating Elevation	Up to 10,000 ft. (3000m) at 104°F (40°C) without derating	
	Storage Elevation	50,000 ft. (15000m) maximum	
	Audible Noise	< 50 dB, at 1 meter from the rear < 45 dB, at 1 meter from the front or sides	
Agency	Safety	CCEE (GB4943-1995) /GB4943	
	RFI/EMI	IEC/EN/AS 62040-2 2nd Ed =CISPR22 Class A	
	Surge Immunity	IEC/EN-61000-4-5, endurance level 3 (2kV) (live line to earth), level 2 (1kV) (during live lines)	

**Battery run time**

Table 2 Battery run time

Battery number	Load	Run time (unit: minute)			
		1kVA	1.5kVA	2kVA	3kVA
Internal Battery	10%	52	112	115	115
	20%	35	47	44	44
	30%	20	26	25	25
	40%	17	20	16	16
	50%	12	13	12	12
	60%	10	10	9	9
	70%	8	8	7	7
	80%	6	7	5	5
	90%	5	5	5	5
	100%	4	4	4	4
Internal Battery + 1 External Battery Cabinet	10%		412	400	220
	20%	136	202	116	120
	30%	115	110	64	102
	40%	90	86	48	60
	50%	66	58	39	52
	60%	58	48	29	44
	70%	50	38	23	34
	80%	43	32	21	27
	90%	41	28	17	25
	100%	27	24	15	18
Internal Battery + 2 External Battery Cabinets	10%		840	540	170
	20%	264	348	231	144
	30%	154	208	138	124
	40%	136	154	99	108
	50%	116	110	64	102
	60%	102	93	55	74
	70%	82	84	48	60
	80%	72	64	41	54
	90%	60	53	36	48
	100%	58	48	29	44
Internal Battery + 3 External Battery Cabinets	10%	620	860	720	295
	20%	360	480	362	230
	30%	224	310	210	174
	40%	162	212	144	130
	50%	128	196	108	114
	60%	124	138	60	105
	70%	116	110	64	102
	80%	108	96	61	80
	90%	80	90	52	68
	100%	78	82	45	62
Internal Battery + 4 External Battery Cabinets	10%	1320	1260	960	236
	20%	640	780	450	204
	30%	500	400	270	184
	40%	224	310	189	168
	50%	174	212	144	132
	60%	136	180	116	120
	70%	140	156	104	108
	80%	124	132	88	103
	90%	116	110	84	102
	100%	109	100	64	84

Note: Approximate discharge times are in minutes and at 77°F (25°C) with a resistive load